

11-1-2004

Anton Webern's Musical Realization of Goethe's Urpflanze Concept in Drei Lieder, Op. 18

Lorian Meyer-Wendt
Florida State University

Recommended Citation

Meyer-Wendt, Lorian, "Anton Webern's Musical Realization of Goethe's Urpflanze Concept in Drei Lieder, Op. 18" (2004). *Electronic Theses, Treatises and Dissertations*. Paper 2453.
<http://diginole.lib.fsu.edu/etd/2453>

This Thesis - Open Access is brought to you for free and open access by the The Graduate School at DigiNole Commons. It has been accepted for inclusion in Electronic Theses, Treatises and Dissertations by an authorized administrator of DigiNole Commons. For more information, please contact lib-ir@fsu.edu.

THE FLORIDA STATE UNIVERSITY
SCHOOL OF MUSIC

ANTON WEBERN'S MUSICAL REALIZATION OF GOETHE'S
URPFLANZE CONCEPT IN DREI LIEDER, OP. 18

By
LORIAN MEYER-WENDT

A Thesis submitted to the
School of Music
in partial fulfillment of the
requirements for the degree of
Master of Music.

Degree Awarded:
Fall Semester, 2004

Copyright © 2004
Lorian Meyer-Wendt
All Rights Reserved

The members of the Committee approve the thesis of Lorian Meyer-Wendt defended on November 1, 2004.

Jane Piper Clendinning
Professor Directing Thesis

James R. Mathes
Committee Member

Denise Von Glahn
Committee Member

Matthew Shaftel
Committee Member

The Office of Graduate Studies has verified and approved the above named committee members.

ACKNOWLEDGMENTS

I offer the utmost gratitude to my thesis advisor, Jane Piper Clendinning, for her support and guidance throughout the duration of this project. Additional acknowledgement goes out to my committee members, Denise Von Glahn, Matthew Shaftel, and James Mathes, for their thoughtful review of this manuscript. I express thanks to Jonathan Leathwood for reviewing drafts of chapters two and six and for helping me with computer formatting issues. An additional thank you goes out to Shirley Trembath for mailing me the pages of her dissertation regarding Op. 18. To my former teaching colleague Joan Zishka, I extend my appreciation for her words of advice on the importance of time management based on her similar experience in balancing full-time teaching with thesis writing. In particular, I wish to thank my principal Mike Munier and the wonderful parents, students, and faculty at Jefferson Academy for the many opportunities and freedoms I have been given to develop musically, invaluable experiences without which this thesis would have remained unfinished. Finally, to my parents I am very grateful for their moral and financial support that made the completion of this project possible.

TABLE OF CONTENTS

List of Figures	v
Abstract	ix
1. INTRODUCTION AND BACKGROUND	1
Scope of the Present Study	15
2. ANALYTICAL TOOLS	17
Pitch Nomenclature	17
Post-Tonal Theoretical Rudiments	18
Bernard's Spatial Arena	25
Marvin and Laprade's Contour Segments	29
Morris's Contour Reduction Algorithm	30
3. OP. 18, NO. 1 ("SCHATZERL KLEIN"): A LOVER'S VISION	33
4. OP. 18, NO. 2 ("ERLÖSUNG"): THE REDEMPTION OF CHRIST	66
5. OP. 18, NO. 3 ("AVE, REGINA COELORUM"): A DEVOTION TO THE VIRGIN MARY	95
6. CONCLUSION AND IMPLICATIONS FOR FURTHER STUDY	118
SELECTED BIBLIOGRAPHY	121
BIOGRAPHICAL SKETCH	126

LIST OF FIGURES

2.1	Pitch Octave Notation	17
2.2	Integer Notation	18
2.3	Interval Nomenclature	19
2.4	Pitch Intervals	19
2.5	Pitch-Class Intervals	20
2.6	Clockface	20
2.7	Interval Vector	21
2.8	Normal Form	22
2.9	Transposition of a Pitch-Class Set	23
2.10	Inversion of a Pitch-Class Set	23
2.11	Z-Related Sets	24
2.12	Complementary Sets	24
2.13	Combinatorial Sets	25
2.14	Row Forms	25
2.15	Pitch-Interval Measurement of a Linear Progression	26
2.16	Mirror and Parallel Symmetry	27
2.17	Projection	27
2.18	Rotation	27
2.19	Expansion and Contraction	28

2.20	Constellation	28
2.21	Contour Segment	30
2.22	Related Forms of a Contour Segment	30
2.23	Contour Reduction Algorithm	31
3.1	Duration Lengths of the Vocal Pitches	34
3.2	“Schatzerl klein,” Rhyme Schema and English Translation	36
3.3	“Schatzerl klein” Row Intervals	37
3.4	Instrumental Introduction, mm. 1-2	41
3.5	Voice and Clarinet Intervals, mm. 2-3	43
3.6	Trichords and Intervals, mm. 3-4	44
3.7	Trichord [5][6], mm. 3-5	45
3.8	Trichords and Intervals, m. 5, bt. 3-m. 6, bt. 2	46
3.9	Trichords and Intervals, m. 6, bt. 3-m. 8, bt. 3	47
3.10	Trichords and Intervals, mm. 8-9	49
3.11	Trichords and Intervals, m. 9, bt. 3-m. 11	50
3.12	Trichords and Intervals, m. 11, bt. 2-m. 13	52
3.13	Sets in the Instrumental Introduction	53
3.14	Guitar Sets in Stanzas Two and Three	56
3.15	Tetrachords 4-Z15 and 4-Z29	58
3.16	Guitar Contours, Stanza One	60
3.17	Voice and Clarinet Contours, mm. 2-3	60
3.18	Vocal Contour <021>, mm. 5-6	62
3.19	Clarinet <021>, mm. 6-8	62

3.20	Vocal Contour <201>, m. 10	64
3.21	Guitar Contour <102>, m. 10, bt. 3-m. 11	64
3.22	Voice Subcontour <120>, m. 12	65
4.1	“Erlösung,” Rhyme Schema and English Translation	67
4.2	Durational Lengths of the Vocal Pitches, Stanza One	68
4.3	Durational Lengths of the Vocal Pitches, Stanza Two, Lines 1-2	69
4.4	Durational Lengths of the Vocal Pitches, Stanza Two, Lines 3-4	69
4.5	Durational Lengths of the Vocal Pitches, Stanza Three	70
4.6	“Erlösung” Row Intervals	71
4.7	Permutations of the Op. 18, no. 2 Row	72
4.8	Opening Clarinet Melody	73
4.9	Guitar Trichords, m. 2, bt. 1	74
4.10	Guitar Intervals, m. 4, bt. 2-m. 5, bt. 1	76
4.11	Guitar Trichords, m. 6, bt. 2	77
4.12	Guitar Trichords, m. 8, bt. 2	78
4.13	Guitar Constellation [5][6], m. 10, bt. 2	79
4.14	Vocal [3][8] Trichordal Outfoldings, m. 16	79
4.15	Clarinet Intervals, m. 16	80
4.16	Guitar Trichords, m. 16	81
4.17	Guitar Tetrachord, m. 18	82
4.18	Contours <2031> and <1302>	87
4.19	Contour <021>, m. 6	89
4.20	Voice Contour, <102>, mm. 6-7	90

4.21	Clarinet Contour <102>, mm. 6-8	90
4.22	Guitar Contour <102>, mm. 2-4	91
4.23	Clarinet Subcontour <021>, mm. 8-9	92
4.24	Clarinet Contour <102>, mm. 11-12	93
4.25	Clarinet and Guitar Contours, mm. 16-18	94
5.1	“Ave, Regina Coelorum” Rhyme Schema and English Translation	95
5.2	Durational Lengths of the Vocal Pitches, Lines 1-2	96
5.3	Durational Lengths of the Vocal Pitches, Lines 3-6	97
5.4	Durational Lengths of the Vocal Pitches, Lines 7-8	98
5.5	T ₄ Row Forms	98
5.6	Op. 18, no. 3 Row Intervals	99
5.7	Vocal Intervals, mm. 9-11	102
5.8	Clarinet UPCI 1s, m. 8, bt. 3-m. 11	104
5.9	Clarinet Intervals, m. 15	105
5.10	Guitar Tetrachord 4-3	109
5.11	Vocal Contour <1032>	111
5.12	Vocal Contours, Stanzas One and Two	112
5.13	Clarinet and Guitar Contours, Instrumental Introduction	112
5.14	Vocal Contour <201>	114
5.15	Instrumental Contour <102>	115
5.16	Instrumental Contour <201>	117

ABSTRACT

Anton Webern first attempted dodecaphonic composition in the summer of 1922 when he wrote twelve-tone sketches for the poetic text “Mein Weg geht jetzt vorüber.” Although he completed the song as an atonal work, Webern continued experimenting with serial writing from 1923-24, composing a series of sketches which led to his exclusive adoption of the technique in fall 1924. After completing two serial works, *Kinderstück* for piano (M. 267) and *Drei Volkstexte*, Op. 17 from 1924-25, Webern composed *Drei Lieder*, Op. 18 in 1925, his first multi-movement work written exclusively within a twelve-tone idiom. Despite this stylistic achievement, Op. 18 has been rarely studied, cited merely as a transitional work leading to Webern’s fuller realization of the technique in his “mature” twelve-tone works. In addition, scholars have erroneously described the intricate musical texture as being chaotic in nature, noting its discrepancy with that of the folkloristic texts on which Op. 18 is based.

The following study establishes an intimate link between the poetic texts and the texture of *Drei Lieder*, Op. 18. The rows imbue the songs with a limited number of interval and set formations that draw associations between words of the individual texts. In addition, recurring contours recall both the mood and narrative events depicted in each poem. These repeated sonorities are interwoven into a texture in which shifting meters, rapidly-changing dynamics, extreme registral shifts, articulation markings, and rhythmic figures enhance their aural presence. Op. 18 represents a musical realization of Goethe’s *Urpflanze* concept, a notion Webern looked to in defining his twelve-tone technique. Just as the *Urpflanze*, or primeval plant, represents an underlying sameness among differing plant parts, the rows and contours establish perceptible aural unity throughout the Op. 18 songs.

CHAPTER ONE

INTRODUCTION AND BACKGROUND

Anton Webern (1883-1945) has been widely celebrated for the skillful canonic writing and symmetry of his instrumental serial works. During the Darmstadt frenzy of the 1950's, the composer's late serial compositions were extolled for exhibiting what was perceived as an incipient extension of dodecaphonic techniques.¹ Following the waning of this short-lived movement, numerous studies highlighting the canonic writing and palindromic features of the composer's twelve-tone instrumental oeuvre came to predominate in the Webern discourse. In keeping with Webern scholarship trends, studies of the dodecaphonic vocal cantatas written during this time also focused on symmetrical traits developed throughout these works, albeit less rigorously.²

Prior to the death of esteemed Webern biographer Hans Moldenhauer in 1987, archival materials hitherto inaccessible to scholars became suddenly available.³ As a result of this accessibility to primary source materials, Webern scholarship trends have shifted from the

¹The Darmstadt Internationales Musikinstitut was founded in 1946 by Wolfgang Steinecke as a center for contemporary music in which summer courses were held annually until 1970. Composers affiliated with Darmstadt such as Pierre Boulez (b. 1925), Karlheinz Stockhausen (b. 1928), and Olivier Messiaen (1908-92) looked to Webern's twelve-tone instrumental works in extending serialism beyond pitch to encompass rhythm, timbre, and dynamics, a compositional procedure known as *total serialism*.

²Although canonic writing as well as symmetrical traits can be found in Webern's dodecaphonic choral output, these compositional devices do not pervade the texture of these works to the extent seen in the twelve-tone instrumental oeuvre. Kathryn Bailey argues that Webern's concern with underscoring the meaning of the poetic text overshadowed his careful adherence to the hitherto-used forms. Kathryn Bailey, *The Twelve-Note Music of Anton Webern: Old Forms in a New Language* (Cambridge: Cambridge University Press, 1991), 266. Catherine Nolan presents a more convincing argument for the absence of symmetrical canons in the twelve-tone choral and solo vocal works based on the limitations of the vocal range. She points out that none of these works contain strictly symmetrical inversions, a technique that lends itself to wide intervallic distances exceeding those of the vocal range. Nolan also notes that, because of their restricted registral capacity, the canonic movements featured in Cantatas Opp. 29 and 31 could not have been written in the style of the instrumental mirror canons. Catherine Nolan, "Hierarchic Linear Structures in Webern's Twelve-Tone Music" (Ph.D. diss., Yale University, 1989), 23, 92.

³Hans Moldenhauer (1906-87) acquired an extensive collection of primary Webern sources from 1961-78 in collaboration with Webern's eldest daughter, Amalie Waller (1911-73). In 1984, he bequeathed the bulk of the holdings to the Paul Sacher Stiftung in Basel, Switzerland.

“cerebral” Webern of the post-Darmstadt era to a more humanistic Webern. The composer’s solo vocal output, which constitutes almost half of his published opus numbers, became the focus of these studies. Examination of the intimate text-texture relationship inherent in his songs inevitably placed the composer within the historical context of his time. Soon after these sources became available, Anne Shreffler studied the fair copies, drafts, and sketches of Webern’s Trakl settings, thereby focusing on the compositional process by which the composer developed his musical ideas. In perusing these sources, she concentrated on the relationship between the texts and the music.⁴ Two recent dissertations by Melanie S. Kronick and Lauriejean Reinhardt examine Webern’s mature twelve-tone vocal works, which were exclusively set to the poetry of Hildegard Jone, in light of the poetic texts and the composer’s friendship with the poet.⁵ Reinhardt specifically cites the recent availability of primary sources and archival materials that helped formulate her musical perspective.⁶

Despite this shifting trend in Webern scholarship, a revisionist view has not yet reached Opp. 17-19. For the most part, the less cerebral, “lyrical” Webern that has been the topic of recent Webern song studies has not been extended to include these works. Rather than being viewed as creations in their own right, Opp. 17-19 have instead been portrayed both as experimental platforms which led to Webern’s exclusive adoption and crystallization of dodecaphony. Divers general Webern studies have reinforced this embryonic depiction of the songs. Wallace McKenzie states that the stylistic traits inherent to Webern’s serial compositions developed in an evolutionary manner, thus implying that the early twelve-tone works did not embody the composer’s unique serial style.⁷ Kathryn Bailey describes Opp. 17-19 as works that

⁴Anne Shreffler examined the fragments, sketches, and fair copies of Webern’s Trakl settings in the fall of 1986 and during the academic year 1987-88 for her 1989 dissertation “Webern’s Trakl Settings,” a work she subsequently revised for her 1994 book *Webern and the Lyric Impulse: Songs and Fragments on Poems of Georg Trakl*. Anne Shreffler, “Webern’s Trakl Settings,” (Ph.D. diss., Harvard University 1989); Anne Shreffler, *Webern and the Lyric Impulse: Songs and Fragments on Poems of Georg Trakl* (Oxford: Oxford University Press, 1994).

⁵Melanie S. Kronick, “Musical Invention and Poetry in the Late Vocal Works of Anton Webern” (Ph.D. diss., The Louisiana State University and Agricultural and Mechanical College, 1992); Lauriejean Reinhardt, “From Poet’s Voice to Composer’s Muse: Text and Music in Hildegard Jone Settings” (Ph.D. diss., The University of North Carolina at Chapel Hill, 1995).

⁶Lauriejean Reinhardt, “From the Poet’s Voice to the Composer’s Muse: Text and Music in Hildegard Jone Settings,” abstract, UMI ProQuest Digital Dissertations, <http://wwwlib.umi.com/dissertations> (accessed October 23, 2004).

⁷Wallace C. McKenzie, Jr., “The Music of Anton Webern,” (Ph.D. diss., North Texas State College, 1960), 376.

systematically outline Webern's progress in formulating his twelve-tone technique.⁸ In his overview of Second Viennese School solo vocal output, Andrew Broekema characterizes Opp. 17 and 18 as works that laid down foundations for Webern's latter twelve-tone writing.⁹ The view of Opp. 17-19 as representations of Webern's initial graspings at serialism is further reinforced by Walter Kolneder.¹⁰ René Leibowitz characterizes Webern's handling of the twelve-tone rows in Opp. 17-19 as being chaotic in nature, a deviance from the characteristic organization of the latter twelve-tone works.¹¹ According to Myra Banks, wider possibilities of serialism only began to first be manifested in String Trio, Op. 20 (1927).¹²

The reputation of Op. 18 as a work inaccessible to analysts has been firmly cemented in numerous studies surveying Webern's compositional output. Outside a handful of cursory remarks on Webern's initial experimentation with twelve-tone composition, the few succinct comments devoted to *Drei Lieder* in these writings do little more than remark on its purported inapproachability. Hayes paints a sharp contrast between the unassuming *Volkslieder* texts and what he describes as Webern's "complex technical" pre-war writing.¹³ Julian Johnson characterizes Op. 18 as a work "impenetrable to most ears," also citing a jarring juxtaposition of the simple folk texts coupled with the song's intricate musical fabric.¹⁴ A similar sentiment is echoed by Sarah Kathryn Yorke who argues that the strict ordering of Webern's dodecaphonic rows results in limited text-interval relations.¹⁵

Several studies offering a more in-depth look at Webern's works by discussing them in

⁸Kathryn Bailey, *The Twelve-Tone Music of Anton Webern*, 33.

⁹Andrew Broekema, "A Stylistic Analysis and Comparison of the Solo Vocal Works of Arnold Schoenberg, Alban Berg, and Anton Webern" (Ph.D. diss., University of Texas at Austin, 1962), 226.

¹⁰Walter Kolneder, *Anton Webern: An Introduction to His Works*, trans. Humphrey Searle (Westport, Conn.: Greenwood Press, 1968), 99.

¹¹René Leibowitz, *Introduction à la musique de douze sons*, Paris: L'Arche, 1949.

¹²Myra Banks, "Anton Webern: Serial Techniques and Formal Principals" (Ph.D. diss., Glasgow University, 1968), 1.

¹³*Ibid.*, 155.

¹⁴Julian Johnson, *Webern and the Transformation of Nature* (Cambridge, England: Cambridge University Press, 1999), 162.

¹⁵Yorke, Sarah Kathryn, "Opera 15-18 of Anton Webern: Musical Choice Inspired by Text" (D.M.A. thesis, University of Cincinnati, 2003), 65.

the context of his sketches also present a portrait of Op. 18 as being unfathomable. Hans Moldenhauer limits his analytical observations on Op. 18 to the rhythmic and contrapuntal complexity of its musical texture.¹⁶ George Perle claims that the associative benchmarks exhibited in Schönberg's early serial endeavors are nowhere to be found in *Drei Lieder*.¹⁷ Anne Shreffler argues that Webern's early adoption of the twelve-tone method resulted in the creation of "irrational and disorganized" vocal works. She ascribes the musical texture of these transitional works as being chaotic in nature, thereby preventing the perception of aural unity.¹⁸ Such emphatic remarks made with a notable dearth of musical examples backing them create the impression that a serious pursuit of Op. 18 will merely lead to frustration.

Two dissertations provide a refreshing change from the prevalent view of Op. 18 as being inscrutable by hinting at the intimacy between the song texts and the musical material: Shirley Trembath's study of Webern's mid-to-late solo vocal works and Andrew Broekema's comparative survey of the solo vocal literature written by the Second Viennese School triumvirate. Although Trembath remarks on the use of large intervals and extreme vocal range in bringing out the expressivity of the Op.18 texts, her comments are limited to pointing out a handful of large intervallic leaps.¹⁹ In addition, her observations on the even distribution of sound and silence for the gay "Scatzerl klein" and the contrastingly irregular placement of rests used to dramatically demarcate phrases and words in "Erlösung" are not extended to include specific examples.²⁰ Along a similar vein, Andrew Broekema touches on Webern's use of particular intervals and chords in creating unity throughout *Drei Lieder*. He lists several sonorities that recur throughout the songs, but does not explicate the manner in which they are positioned among the voice, clarinet, and guitar in accentuating the meaning of the poetic texts.²¹

¹⁶ Hans Moldenhauer and Rosaleen Moldenhauer, *Anton von Webern: A Chronicle of His Life and Work* (New York: Alfred A. Knopf, 1979), 317.

¹⁷George Perle, "Webern's Twelve-Tone Sketches," *The Musical Quarterly* 7, no. 1 (1971): 4-5.

¹⁸Anne Shreffler, "'Mein Weg geht jetzt vorüber': The Vocal Origins of Webern's Twelve-Tone Composition," *Journal of the American Musicological Society* 47, no. 2 (Summer 1994): 276-7.

¹⁹Shirley Trembath, "Text and Texture in the Solo Vocal Works, Opp. 14-25, of Anton Webern" (Ph. D. diss., University of Texas at Austin, 1985), 205, 211.

²⁰*Ibid.*, 131-33.

²¹Andrew Broekema, "A Stylistic Analysis and Comparison of the Solo Vocal Works of Arnold Schoenberg, Alban Berg, and Anton Webern," 269-73, 295.

In a similar manner, Robert Jeffers outlines recurring intervals, rhythms, and motivic phrases that recur throughout Op. 18 without relating them to the poetic language of the three poems.²²

Two additional studies establish the close-knit relationship between the music and the poetic texts of Op. 18. Dorothea Beckmann verifies the intimate connection between the texts and music by means of numerous musical examples interspersed throughout her stylistic study of Webern's solo vocal works. The correspondence between poetic stresses and musical accents is corroborated, notably with two essential textual-musical references in "Erlösung": Webern's musical response to its irregular, speech-like poetic text, and the extreme registral placement of the pitches marking the beginning of each dialogue.²³ Beckmann also points out musical markings signaling repeated words, rhyming words, and words of significance in the three songs of Op. 18.²⁴ In addition, she presents a contrastingly critical stance in noting a discrepancy between the intricate musical surface of Op. 18 and the simplicity of the folk texts. Beckmann points to the plethora of extreme intervallic leaps as being in danger of losing their effectiveness.²⁵ Joachim Noller observes that the music responds to the texts, not by means of extramusical associations, but through clarification of the poetic forms, a point clearly displayed through the separation of the simple stanzas by *ritardando* markings in "Schatzerl klein" and the musical isolation of words in the irregular, speech-like "Erlösung."²⁶ He also points to the unity established throughout Op. 18 by means of horizontal and vertical tone associations, a characteristic feature of Webern's works.²⁷

Valentina Cholopowa and Juri Cholopow argue that the dodecaphonic musical material in Opp. 17-19 differs little stylistically from the vocal "middle" works, instead pointing to the

²²Robert E. Jeffers, "An Analysis of Webern's Op. 18" (D.M.A. thesis, University of Illinois, Urbana-Champaign, 1983).

²³Dorothea Beckmann, *Sprache und Musik im Vokalwerk Anton Weberns: Die Konstruktion des Ausdrucks* (Regensburg: Bosse, 1970), 35, 130, 50

²⁴*Ibid.*, 73, 128-9, 141, 193.

²⁵*Ibid.*, 41, 228.

²⁶Joachim Noller, "Das dodekaphone Volkslied," in *Anton Webern II*, ed. Heinz-Klaus Metzger and Rainer Riehm (Munich: Musik-Konzepte Sonderband, 1984), 149.

²⁷*Ibid.*, 139, 144-5.

importance of Opp. 21 and 22 in marking a decisive compositional turning point for Webern.²⁸ The significance of Webern's initial dodecaphonic achievements is overshadowed by the authors' emphasis on the symmetrical and canonic features characteristic of the latter works. I argue instead that Opp. 17-19 are crowning achievements, whose importance can be further understood in light of the numerous unfinished twelve-tone fragments that preceded them. Op. 18 stands at the cusp of Webern's musical development in displaying increasingly complex series organization within the genre of the solo vocal song, the final product in an uninterrupted ten-year streak of solo vocal composition. In order to better understand the pivotal position occupied by Op. 18, a summary of the conditions leading to Webern's assimilation of twelve-tone techniques is in order.

In 1904, Webern began his compositional studies with Arnold Schönberg (1874-1951) along with Alban Berg (1885-1935). During this intensive four-year period, rigorous contrapuntal and harmonic studies placed within the framework of the Austro-Germanic music tradition formed the basis of Schönberg's teachings. Beginning in 1908, the three composers embarked on a compositional journey in which post-Wagnerian chromaticism was pushed beyond its tonal framework. Schönberg, Berg, and Webern began increasingly to insert chromatic sonorities into their works, relegating tonal sonorities to a vestigial function. Without a musical language with which to structure their works, however, a means of developing a large-scale instrumental work was lost. The three composers instead relied on poetic texts to create extended atonal vocal works.²⁹ Webern turned exclusively to the *Lied* in composing Opp. 12-19, his atonal and initial twelve-tone works, during a fruitful period of composition that extended from 1915 to 1926.³⁰ Webern's cultivation of atonality within the genre of the *Lied* placed him in line with a longstanding German music tradition. His prominent, syllabic vocal lines, limited

²⁸Valentina Cholopowa and Juri Cholopow, *Anton Webern: Leben und Werk*, trans. Christoph Hellmundt (Berlin: Henschelverlag, 1989), 277.

²⁹Webern composed his aphoristic atonal works, Opp. 3-11 from 1908-14. His crisis in developing longer musical forms is most dramatically exemplified in the fourth movement of his orchestral piece *Five Pieces*, Op. 10 (1911), a work that encompasses a mere six measures.

³⁰As a part of the early twentieth-century "lyrische Kultur," Webern was an avid reader of poetry anthologies which in turn inspired him to write his vocal compositions. Elizabeth West Marvin and Robert W. Wason, "On Preparing Anton Webern's Early Songs for Performance: A Collaborator's Dialogue," *Theory and Practice* 20 (1995): 92. Vocal music formed a large component of the humanistic curriculum at the *Bundesgymnasium* (1894-1902) in Klagenfurt, Austria, a subject in which Webern always received high marks. Hans Moldenhauer and Rosaleen Moldenhauer, *Anton von Webern: A Chronicle of His Life and Work*, 34.

harmonic vocabulary, and musical accommodations to the poetic texts recall a *Lieder* tradition that extended back from Mahler and Wolf to Schubert.³¹ In adopting a stance espoused by Schönberg, Webern did not view his renunciation of tonality as a break with German musical tradition. Instead, he regarded distantly removed overtones as differing only in degree from their consonant counterparts.³² In February 1923, Schönberg unveiled to a select number of affiliates at his home in Mödling his method of “composition with twelve tones related only to one another,” an ordered structuring of twelve pitches.³³ In seeking a means with which to organize the dense chromaticism of their atonal works, Schönberg, Webern and Berg turned to twelve-tone writing.

Webern first attempted dodecaphonic composition in the summer of 1922 when he wrote a series of sketches for the poetic text “Mein Weg geht jetzt vorüber.”³⁴ The composer based these sketches on permutations of the row, but completed the work in an atonal idiom that retained only remnants of the row forms. Webern continued to experiment with serial writing from 1923-24, during which time he composed a number of sketches that led to his exclusive adoption of the technique in 1924. In autumn 1924, Webern completed his first twelve-tone composition, *Kinderstück* for piano (M. 267), a work built from seven abutting linear row forms. During that same year, he set music to the poetic text “Armer Sünder, du” based on the partial use of harmonic dodecaphonic ordering. Webern completed two more twelve-tone songs in July

³¹Anne Shreffler, *Webern and the Lyric Impulse: Songs and Fragments on Poems of Georg Trakl*.

³²Arnold Schönberg, *Theory of Harmony*, trans. Roy E. Carter (Berkeley: University of California Press, 1978), 20; Anton Webern, *Path to New Music*, ed. Willi Reich, trans. Leo Black (London: Theodore Presser, 1963), 16.

³³Translation by the author. “Komposition mit zwölf nur aufeinander bezogenen Tönen.” Moldenhauer and Moldenhauer, *Anton von Webern: Chronik seines Lebens und Werkes*, trans. Ken W. Bartlett (New York: Knopf, 1980) 227.

³⁴Schönberg claimed in his 1951 essay “I ..immediately and exhaustively explained to him [Webern] each of my new ideas (with the exception of the method of composition with twelve tones—that I long kept secret, because, as I said to Erwin Stein, Webern immediately used everything I do.... Arnold Schönberg, “Anton Webern: Klangfarbenmelodie,” in *Style and Idea*, ed. Leonard Stein (New York: St. Martin’s Press, 1975), 484. However, an exchange of letters from 1915-17 between Schönberg and Webern includes a discussion of a twelve-tone theme drafted by Schönberg for an instrumental scherzo in his unfinished oratorio *Die Jakobsleiter* (1917-22). Webern’s use of the twelve-tone techniques in “Mein Weg geht jetzt vorüber” precedes Schönberg’s February 1923 meeting as well as his teacher’s composing of a twelve-tone row and assimilation of the particular serial techniques employed in the sketch into his own works. Lauriejean Reinhardt, “Anton Webern’s ‘Mein Weg geht jetzt vorüber,’ op. 15, No. 4,” in *The Rosaleen Moldenhauer Memorial: Music History from Primary Sources: A Guide to the Moldenhauer Archives*, ed. Jon Newsom and Alfred Mann (Washington: Library of Congress, 2000), 458.

1925 which were posthumously joined with “Armer Sünder, du” in forming Three Traditional Rhymes, Op. 17. The second and third songs are also built from harmonic row statements, the second presenting a strict ordering of the twelve-tone rows.

Soon after completing the songs of Op. 17, Webern composed *Drei Lieder*, Op. 18, his first multi-movement work written exclusively in a twelve-tone idiom. Similar to Op. 17, the first two songs are built from harmonic row statements and are based on separate rows. Webern completed “Schatzerl klein” on 10 September 1925, a work constructed from consecutive statements of a prime row. This was followed by the completion of “Erlösung” on 27 September, his first work to feature permutations of the prime row. While composing the third song, “Ave, Regina coelorum,” Webern wrote to Berg of his adaption to the new dodecaphonic method:

The twelve-tone technique has become for me a completely clear procedure. Of course, all these songs are written this way. I derive a satisfaction from this work that I have seldom experienced before.³⁵

Webern completed the third song on 28 October as a work based on linear permutations of the row, a technique he exclusively employed throughout the remainder of his compositional output.³⁶ The work was subsequently published by Universal Edition in 1927. He based the choral setting of *Zwei Lieder*, Op. 19 on a single row, another device he would exploit throughout the remainder of his oeuvre. Following a thirteen-year hiatus, Webern returned to instrumental composition with his *String Trio*, Op. 20 (1926-7), a work whose incipient display of symmetrical and canonic features was fully realized in his *Symphony*, Op. 21 (1927-8).

Webern looked to Johann Wolfgang von Goethe’s pantheistic *Urpflanze* concept in developing his ideas about the twelve-tone row. He outlined the premises of the *Urpflanze*, or

³⁵Translation by the author. “Die Zwölftonkomposition ist mir jetzt eine bereits vollkommen klare Sache. Natürlich sind diese Lieder alle darin geschrieben. Und diese Arbeit bereitet mir Vergnügen wie noch selten zuvor.” Letter from Anton Webern to Alban Berg, October 8 1925, *Opus Anton Webern*, ed. Dieter Rexroth (Berlin: Quadriga, 1983), 91.

³⁶The sketches for Op. 18 nos. 1 and 2, as well as the fair copy of Op. 18, are located in the Robert Owen Lehman Collection of the Pierpont Morgan Library in New York. Lehman acquired the sketchbook in 1976 from Universal Edition. These sketches form a part of Sketchbook I (1925-26), and also contain some of the sketches for Op. 18, no. 3. Loose-leaf sketches of the third song are also located in the Paul Sacher Stiftung. For a thorough description of the sketchbook and loose-leaf contents, see Donna Lynn’s dissertation “Genesis, Process and Reception of Anton Webern’s Twelve-Tone Music: A Study of the Sketches for Opp. 17-19, 21, and 22/2 (1924-30)” (Duke University, 1992), 99-127.

primeval plant, an underlying sameness that connects different plant parts to one another, in his *Weg zur neuen Musik* (Path to New Music) lectures. These multifarious manifestations of the *Urpflanze* are in turn a reflection of divinity. As Goethe does not see a contrast between a product of nature and a product of art, the ordering of the twelve-tone row embodies a natural law connected to divinity. Just as different plant parts can be identified as belonging to the same plant, Webern argues that the underlying unity of the row must on some level be aurally perceptible to the listener.³⁷ Almost thirty years earlier, he outlined the *Urpflanze* concept in his diary, a notion Gustav Mahler (1860-1911) expounded in connection with music following a 3 February 1905 *Liederabend* (evening of songs).³⁸

In composing Op. 18, Webern set music to three texts stemming from divergent sources. His unusual, eclectic selection of texts was modeled after a prayer uttered by the character Dr. Marianus, a mystical scholar of the Middle Ages who appears in the final scene of Goethe's *Faust II*. Webern explained the connection between the texts in a letter written to Emil Hertzka, the director of Universal Edition:

The three songs, the first modeled on a folkloristic bridal song, the second, "Erlösung," derived from *Des Knaben Wunderhorn*, the third, a Latin Marian hymn, form a united whole, much like Dr. Marianus's invocation from the second part of *Faust*: "Virgin, Mother, Heavenly Queen."³⁹

Webern became thoroughly acquainted with Goethe's text while performing the celesta part of Mahler's Eighth Symphony under Alexander Zemlinsky in Prague during March 1912. The second part of the massive Eighth Symphony depicts the closing scene of *Faust II* in a choral setting. Webern, a lifelong Roman Catholic, adopted Goethe's phrase as a term of endearment for his wife Wilhelmine (Minna) Webern. Webern's daughter Amalie Waller recalled her father

³⁷Anton Webern, *The Path to New Music*, ed. Willi Reich, trans. Leo Black, 10-11, 40-41, 55. *The Path to New Music* is a compilation of the lectures given by Webern at the home of physician and music lover Dr. Rudolph Kurzmann from 15 January to 2 March 1932 and 20 February to 10 April 1933.

³⁸Hans Moldenhauer and Rosaleen Moldenhauer, *Anton Webern: A Chronicle of his Life and Work*, 75.

³⁹Translation by the author. "Die drei Lieder, das erste nach einem volkstümlichen Brautlied, das zweite nach einem Wunderhornlied 'Erlösung,' das dritte nach einem lateinischen Marienhymnus, bilden ein geschlossenes Ganzes, etwa im Sinne der Anrufung des Dr. Marianus aus dem II. Teile des 'Faust': 'Jungfrau,' Mutter, Himmelskönigin." Letter from Anton Webern to Emil Hertzka, 2 February 1926, *Anton Webern 1883-1983*, ed. Ernst Hilmar (Vienna: Universal Edition, 1983), 76

as having fondly referred to her mother as “Minna-Mutter-Königen” (Minna-Mother-Queen).⁴⁰

For the first song of Op. 18, Webern set music to the simple, folkloristic poem “Schatzerl klein” (Little Sweetheart) written by Austrian novelist Peter Rosegger (1843-1918). As in the composer’s other song publications bearing Rosegger texts, however, he does not indicate authorship for “Schatzerl klein.”⁴¹ Peter Andraschke speculates that Webern might have indeed believed the folk poetry embedded throughout Rosegger’s vernacular novels and narrative fiction to be anonymous relics of the *Volkslied* tradition. After conducting a thorough search through the extensive holdings of the German Volkslied archive in Freiburg im Breisgau, Andraschke deduced that many of the hitherto unidentified poetic texts found in Rosegger’s writings were in fact penned by Rosegger himself.⁴²

Webern’s selection of “Schatzerl Klein” from Rosegger’s *Das Buch der Novellen II* reflects his strong affinity for the simple, direct language and religious overtones characteristic of Rosegger’s novels and the poems sprinkled throughout them. Webern’s choice of poetry from this source comes as no surprise, as he was an avid reader of Rosegger’s novels.⁴³ The composer’s emotive response to the writings of Rosegger is vividly depicted in a letter he sent to Schönberg in December 1912:

My dearest friend, allow me to place a copy of Rosegger’s book “Waldheimat” (*Home in the Forest*) underneath your Christmas tree. The book is about Rosegger’s youth. The last chapter is titled “from my mother.” This chapter contains unspeakably beautiful words: “...finally, the tears came. The tears that the mother’s heart once gave us as comfort in suffering and as the sole consolation in the hour when no other salvation for the soul is near, when friends can no longer understand us, and when the mother’s heart is

⁴⁰Hans Moldenhauer and Rosaleen Moldenhauer: *Anton von Webern: A Chronicle of His Life and Work*, 317.

⁴¹In addition to Op. 18, no. 1, Webern set music to Rosegger texts for the following solo vocal works: Op. 12, no. 1 “Der Tag is vergangen” (1915), Op. 15, no. 1 “Das Kreuz, das muß’ er tragen” (1921), Op. 15, no. 3 “In Gottes Namen aufstehn” (1921), Op. 15, no. 5 “Fahr hin, o Seel” (1917), Op. 17, no. 1 “Armer Sünder, du” (1924), and Op. 17, no. 2 “Liebste Jungfrau” (1925).

⁴² Peter Andraschke, “Webern und Rosegger,” in *Opus Anton Webern*, ed. Dieter Rexroth (Berlin: Quadriga, 1983), 108.

⁴³As a keen mountaineer, Webern turned to Rosegger’s Alpine novels in order to alleviate his homesickness when removed from his native Austrian Alps. He read them while working as a conductor at the Stettin summer theater in 1912 and during his brief sojourn in June 1922 to the Allgemeine Deutsche Tonkünstlerfest in Düsseldorf where he conducted his Passacaglia. In the summer of 1913, Webern made a pilgrimage to Rosegger’s birthplace, a peasant hut located in the Austrian Alps, and visited a schoolhouse founded by the author in the nearby vicinity.

broken. O hail, you rich, eternal heritage!" I beg you, if I should experience the extraordinary pleasure of having you conduct my orchestral works, to reflect upon these words.⁴⁴

Webern's strong affiliation with Rosegger's words is underscored by his belief in their expressive potential for coloring the way Schönberg conducted his orchestral works.

The references to flowers in "Schatzerl klein" were likely an impetus for Webern in his selection of the poem, as he had an avid interest in them. Webern's passion is evinced by the frequent descriptions of flowers found interspersed throughout his diaries and letters, as well as by the collection of pressed mountain flowers he kept among his souvenirs. In addition, Webern habitually carried a botanical lexicon on his frequent mountain excursions in order to learn more about mountain flora. He believed that a physical knowledge of flowers as manifestations of nature would lead to a metaphysical understanding of the natural world, a notion stemming from Goethe's *Urpflanz* concept.⁴⁵ In a letter written to Berg, Webern ascribed the rosemary in "Schatzerl klein" to a divine paradigm that would point towards the underlying essence of the song's musical form.⁴⁶

The poetic text for Op. 18, No. 2, "Erlösung" (Redemption), comes from the third volume of *Des Knaben Wunderhorn*, an eclectic three-volume collection of Germanic folk poems compiled and edited by German writers Ludwig Achim von Arnim (1781-1831) and Clemens Brentano (1778-1842). The first volume was published in 1806, and the second two in 1808. The topics dealt with in this vast collection of folk poetry range from the historical and religious to the secular. Many of the poems in *Des Knaben Wunderhorn* were copied by Arnim from old songbooks. Both Brentano and Arnim placed their own poems into the collection, as well as altering many of the original texts: Brentano added dialectic effects in order to bring out

⁴⁴Translation by the author. "Liebster Freund, erlaube, daß ich Dir diesmal das Buch Roseggers 'Waldheimat' unter den Weihnachtsbaum lege. Es handelt von der Jugend Roseggers. Das letzte Kapitel heißt 'von meiner Mutter'. Da drin stehn diese für mich unsagbar schönen Worte: '...endlich kam die Thräne. Die Thräne, die uns einst das Mutterherz mitgegeben auf die Welt zur Linderung im Leid und zum einzigen Trost in der Stunde, wo kein anderes Heil der Seele naht, wo die Freunde uns nicht verstehen können und das Mutterherz gebrochen ist. O sei begrüßt, du reiches, ewiges Erbe!' Ich bitte Dich, wenn mir wirklich das unerhörte Glück zu Teil werden sollte, daß Du meine Orchesterstücke dirigierst, dann an diese Worte zu denken." Peter Andraschke, "Webern und Rosegger," 111.

⁴⁵Letter from Anton Webern to Alban Berg, 1 August 1919, in *Anton von Webern: A Chronicle of his Life and Work*, Hans Moldenhauer and Rosaleen Moldenhauer, 231.

⁴⁶Letter from Anton Webern to Alban Berg, 25 October 1925, in *Opus Anton Webern*, ed. Dieter Rexroth, 90-1.

the folkloristic nature of the poetry and Armin inserted strains of contemporary sentiment into the old texts.⁴⁷

Although numerous composers, such as Schumann and Brahms, set musical works to *Des Knaben Wunderhorn* following its publication, it was likely the figure of Mahler that influenced Webern's choice of text for the second song.⁴⁸ On 3 February 1905, Webern attended a concert of Mahler's songs under the auspices of the short-lived *Vereinigung schaffender Tonkünstler* (Society of Creative Musicians) during which songs from the *Wunderhorn* cycle were played.⁴⁹ After the performance, he attended a social gathering where Mahler shared many of his musical convictions. Webern recorded his profound reaction to the evening in his diary:

Those hours spent in his presence shall always remain the happiest in my memory, since it was the first time that I was under the direct impression of a truly great personality.⁵⁰

In addition, the straightforward message expressed through the unadorned language of "Erlösung" no doubt attracted the composer, who felt such a strong affinity for Rosegger's direct writing style.

Webern set music to the Marian antiphon "Ave, Regina coelorum" (Hail, Holy Queen) for the third song of Op. 18. Marian antiphons are devotional liturgical chants dedicated to Mary that belong to the Gregorian chant repertory. They were sung by monks during the Hours of the Office, a schedule of worship established by St. Benedict (ca. 480-527) around which the monastic day of work and study was arranged. It is likely that "Ave, Regina coelorum" along with the Marian antiphon "Alma redemptoris mater" were originally sung together in conjunction with a psalm.⁵¹ "Ave, Regina coelorum" came to be affiliated separately, however,

⁴⁷Roland Hoermann, *Achim von Arnim* (Boston: Twayne, 1984), 23.

⁴⁸Prior to composing Op. 18, Webern set music to the poem "Dormi Jesu" from *Des Knaben Wunderhorn*, the second song of *Five Canons on Latin Texts*, Op. 16 (1923).

⁴⁹The Society of Creative Musicians was founded in 1904 by Arnold Schönberg and Alexander Zemlinsky for the purpose of promoting contemporary music. It lasted until 1905 following a successful concert season. Mahler presided as honorary president during the society's short tenure.

⁵⁰Translation by the author. Hans Moldenhauer and Rosaleen Moldenhauer, *Anton von Webern: Chronik seines Lebens und Werkes*, 65. "Diese in seiner Gegenwart verbrachten Stunden werden mir stets als überaus glückliche in Erinnerung sein, war es doch zum erstenmal, daß ich unter der unmittelbaren Einwirkung einer wahrhaft großen Persönlichkeit stand."

⁵¹Michel Huglo and Joan Halmo, "Antiphon," in *The New Grove Dictionary of Music and Musicians* 1, 2d

with the time of the liturgical year spanning from Purification (2 February) to the Wednesday of Holy Week, the last week before Easter. Webern's use of the Latin antiphon probably resulted from his having borrowed a Roman Catholic breviary from a priest in July 1923 for the purpose of composing *Five Canons on Latin Texts*, Op. 16.⁵²

In addition to the obvious connection of the "Schatzerl klein" and "Erlösung" texts to the rich *Volkslied* tradition, the musical texture of Op. 18 bears strong ties to the Germanic *Volkslied* tradition. Webern cast the folkloristic love poem "Schatzerl klein" as a slow-moving song in 3/4 meter, evoking a Ländler, a traditional Germanic folkdance for couples. The inclusion of the guitar as an accompaniment to the folkloristic texts evokes the immensely popular Germanic *Wandervogel* movement, a youth movement begun in 1896 that espoused a love for hiking and nature.⁵³ Portable instruments such as the guitar and mandolin, were carried to the outdoors by the *Wandervögel* on their hiking and camping excursions. Webern himself was an avid mountaineer who frequented the Austrian Alps in the spirit of the widespread *Wandervogel* movement.

Webern's instrumental setting of Op. 18 for voice, clarinet, and guitar recalls an immensely popular folkloristic music tradition of the time: the ubiquitous sound of *Schrammelmusik* heard throughout Vienna in casual settings such as inns, wine gardens (*Heurige Gärten*), and cafés, a music tradition that has thrived to the present day, and the immensely popular Germanic *Wandervogel* movement. The tradition of *Schrammelmusik* originated with the formation of the Schrammel Trio in 1878 by violinist brothers Josef Schrammel (1852-1895) and Johann Schrammel (1850-1893), as well as bass guitarist Anton Strohmayer (1848-1938) who replaced guitarist Draskovits in 1879. In that year, clarinetist Georg Dänzer began playing his high-pitched G clarinet with the trio, leading to the official formation of a quartet in 1886. Both Johann and Josef Schrammel composed songs and dances for the ensemble, Johann Schrammel being the more prolific of the two. Following Dänzer's death upon return from a

ed., Stanley Sadie (New York: MacMillan, 2001), 746.

⁵²Four of the five Op. 16 texts form part of the liturgy of the Mass: "Christus factus est" is the Gradual from the Solemn evening Mass for Maundy Thursday, "Crux fidelis" is a hymn from the Solemn afternoon Liturgy for Good Friday, "Asperges me" is a Psalm verse commonly sung as an antiphon to the Sunday Mass, and "Crucem tuam adoramus" is an antiphon from the Solemn afternoon Liturgy for Good Friday.

⁵³Hitler outlawed all existing youth movements and founded the *Hitlerjugend* (Hitler Youth Movement) in 1933.

guest appearance of the Schrammel Quartet at the Chicago World Fair in 1893, the clarinetist was replaced by an accordion player. Many ensembles formed themselves after the Schrammel Quartet, leading to the adoption of the term *Schrammelmusik*. Webern's Op. 18 setting of the guitar and the E-flat clarinet, whose high-pitched notes are not dissimilar to the G clarinet of the Schrammel Quartet, to the folkloristic poetry of Op. 18 points to this popular Viennese music tradition.

Webern was inspired both by Mahler and Schönberg to incorporate the guitar, with its expressive timbral palette, into Op. 18.⁵⁴ Mahler composed the two "Night Music" movements of the vast Seventh Symphony in 1904 after having conducted Verdi's *Falstaff* at the *Hofoper* (Vienna Court Opera) in May 1904, an opera that features a brief guitar solo. The guitar coupled with the mandolin are clearly heard in the delicate, sparsely scored movement. Schönberg attended a Vienna performance of the Seventh Symphony on 3 November 1909, and Webern a Berlin performance during fall 1910. In an essay written in praise of Mahler a year after his death, Schönberg commented on the late composer's scoring of the guitar in the Seventh Symphony:

The guitar in the seventh is not introduced for a single effect, but the whole movement is based on this sonority. It belongs to it from the very beginning, it is a living organ of the composition: not the heart, but perhaps the eyes, whose glance is so characteristic of its aspect.⁵⁵

In May 1920, Schönberg attended another performance of Mahler's Seventh Symphony performed by the Concertgebouw Orchestra under Willem Mengelberg (1871-1951) at the Mahler Festival in Amsterdam. During that same year, he began composing his Serenade, Op. 24 for clarinet, bass clarinet, mandolin, guitar, violin, viola, cello, and bass voice, a transitional twelve-tone ensemble work that includes the guitar (1920-23).⁵⁶ A year after its completion in

⁵⁴Webern also incorporated the guitar into his Five Pieces for Orchestra, Op. 10 (1911-13). He selected these pieces from a series of movements, three of which were posthumously published by Carl Fischer in 1968 as Three Orchestral Songs (1913-14) and five in 1971 as Orchestra Pieces (1913). In addition, Webern composed Zwei Lieder, Op. 19 for mixed chorus, celesta, guitar, violin, clarinet and bass clarinet (1925-6). Unlike Schönberg, Webern invariably composed on the piano, a fact ascertained by English composer Humphrey Searle (1915-82), a student of Webern from 1937-8. Hans Moldenhauer and Rosaleen Moldenhauer, *Anton von Webern: A Chronicle of His Life and Works*, 513.

⁵⁵Arnold Schönberg, "Gustav Mahler" in *Style and Idea*, ed. Leonard Stein, 463-4. Schönberg wrote this essay in 1912, and subsequently revised it in English in 1948.

⁵⁶Although each of the movements employs twelve-tone procedures, the fourth movement Sonett No. 217

1923, Webern conducted the rehearsals for the private premiere of the work on 2 May 1924 at the home of arts benefactor Norbert Schwarzmann. Webern also voiced a love for the second “Night Music” which no doubt influenced his inclusion of the guitar in Op. 18. In a letter written to Hildegard Jone on 21 April 1934, Webern described his reaction to having conducted Mahler’s seventh symphony in London:

I am conducting...the two “Night Musics” from Mahler’s Seventh Symphony. The second, in particular, is a work of indescribable splendor. Nothing else sounds but love, love, love.⁵⁷

Scope of the Present Study

The present study is an attempt to transcend the seemingly impermeable surface difficulty of *Drei Lieder*, Op.18, which has clouded the perception of this work by analysts, and to unearth underlying formal structures that pervade its musical texture. My examination of each song begins necessarily by analyzing the form and content of the poems Webern set to music. The composer’s conception of the musical material for his vocal works derived from his reading of the poetic texts:

...I have *never* had the intention—I *cannot even have such an intention*—to write a vocal composition (a song, a choral work, etc), so to speak, looking for a “text.” It was never so; *the text was always given first!* Once the text was there, a “vocal work” would come into being as a result of this text.⁵⁸

von Petrarca is the only one based on a twelve-tone row. Schönberg also included the guitar in his instrumentation exercises (summer 1921) of Franz Schubert’s *Ständchen* (“Hark! Hark! the Lark”) D 889 for voice, clarinet, bassoon, mandolin, guitar, and string quartet, Luigi Denza’s “*Funiculi, funiculà*” for clarinet, guitar, mandolin, and string trio, and Johann Sioly’s “*Weil i a alter Dreher bin*” for clarinet, guitar, mandolin, and string trio. In addition, he incorporated the guitar into his one-act opera *Von heute auf morgen* (1928-29) and his unfinished three-act opera *Moses und Aaron* (1930-32). In composing his guitar chamber works, Schönberg built a paper-mache guitar with which he tested the feasibility of the guitar fingerings in his compositions. David Franklin, Jr. Marriott, “Contemporary Guitar Composition: Experimental and Functional Practices since the ‘Second Viennese School,’” (Ph.d. diss., University of California at San Diego, 1984), 39-40. Marriott obtained this information from Leonard Stein, Schönberg’s assistant and editor of his books on theory and composition, in April, 1981.

⁵⁷Translation by the author. “Ich dirigiere...die beiden “*Nachtmusiken*” aus der VII. Symphonie von Mahler...Namentlich die zweite ist von unbeschreiblicher Herrlichkeit. Da tönt wohl nichts als Liebe, Liebe, Liebe.” Anton Webern., *Briefe an Hildegard Jone und Josef Humplik*, ed. Joseph Polnauer (Vienna: Universal Edition, 1959), 26.

⁵⁸Translation by the author. Letter from Anton Webern to Hildegard Jone, 2 March 1941, in *Letters to Hildegard Jone and Josef Humplik*, ed. Josef Polnauer, trans. Cornelius Cardew (Bryn Mawr, Pa.: Theodore Presser, 1967), 43. “...*nie* bin ich etwa in der Absicht--*ich kann die ja gar nicht haben--*, Vokales (ein Lied, einen Chor usf.) zu schreiben, gewissermaßen auf Ausschau nach einem ‘Text’ gegangen. Nie war es so, sondern *immer war der zuerst gegeben!* War er aber da, dann sollte wohl eben ‘Vokales’ entstehen.” Anton Webern., *Briefe an Hildegard*

Next, I will summarize the intervals and set imbrications that capture the sound of each row. I will then present the findings of my theoretical investigation attained by means of several different analytical procedures.⁵⁹ A discussion of the distinctive individual parts and their interaction with one another in elucidating the meaning of the poems will shape this discourse. Jonathan Bernard's spatial environment brings to the fore the pitch intervals that transform into related forms during the course of developing musical events. Allen Forte's set classes define the interval-class makeup of the individual parts as well as their interrelation with one another. Elizabeth Marvin West and Marvin LaPrade's c-segments and Robert Morris's contour reduction algorithm highlight the similarities of relative pitch placement in various melodic strands. Throughout my colloquy, I will make frequent musical references to the *Drei Lieder*, Op. 18 score, a copy of which the reader will need to have in hand.⁶⁰

Jone und Josef Humplik, 45-6.

⁵⁹A thorough explanation of these analytical procedures can be found on pages 17-32.

⁶⁰Anton Webern, *Drei Lieder für Gesang, Es-Klarinette und Gitarre*, Op. 18 (Vienna: Universal Edition), 1954.

CHAPTER 2

ANALYTICAL TOOLS

The following section was written with the awareness that a musician wishing to explore my theoretical perspective of *Drei Lieder* may or may not have a background in post-tonal analysis. I have thus provided brief explanations and background information on the analytical procedures applied to the musical fabric of Op. 18. In order to facilitate the reading of this chapter, the name of each analytical tool is placed in italics, accompanied by a musical example illustrating its given application so that it may easily be referred to throughout the course of reading.

Pitch Nomenclature

The Acoustical Society of America's system of pitch nomenclature has been adopted for the present study. In this taxonomy, pitches are identified with capital letters followed by numerals that indicate octave placement. C0 represents the lowest audible pitch to the human ear, thereby designating middle C as C4 (fig. 2.1).

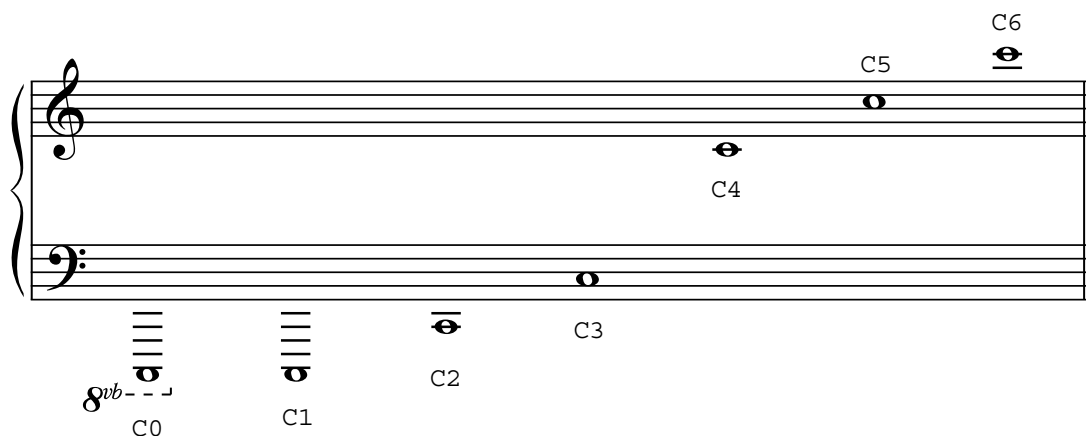

Fig. 2.1. Pitch Octave Notation

Post-Tonal Theoretical Rudiments

Ease in understanding the post-tonal theoretical tools used in the present study is predicated on a mastery of several basic interval types. Distances between *itches*, notes defined by their exact frequency, and *itch classes*, notes with the same letter name, are used to specify these intervals. In marked contrast to tonal music, enharmonically equivalent pitches do not bear different functions in post-tonal music. A series of twelve integers spanning from zero to eleven that represent each pitch class (PC) replaces standard notation of enharmonically equivalent pitches (fig. 2.2).

0	B#, C
1	C#, D \flat
2	D
3	D#, E \flat
4	E, F \flat
5	E#, F
6	F#, G \flat
7	G
8	G#, A \flat
9	A
10	A#, B \flat
11	B, C \flat

Figure 2.2. Integer Notation

Following suit, intervals are not identified with traditional interval names denoting dissimilar tonal functions, but by measurements of semitones (fig. 2.3).

1	m2
2	M2, d3
3	A2, m3
4	M3, d4
5	A3, P4
6	A4, d5
7	P5, d6
8	A5, m6
9	M6, d7
10	A6, m7
11	M7, d8
12	A7, P8

Fig. 2.3. Interval Nomenclature

Four different means of calculating distances between pitches and pitch classes serve to define intervals in post-tonal theory. The value of a *pitch interval* is determined by counting the number of semitones between two pitches. The direction in which the pitches are moving is identified by plus and minus signs appearing before *ordered pitch intervals* (OPI) (fig. 2.4a). An *unordered pitch interval* (UPI) is a computation of the span between two pitches without an indication of the direction in which they are moving (fig. 2.4 b).

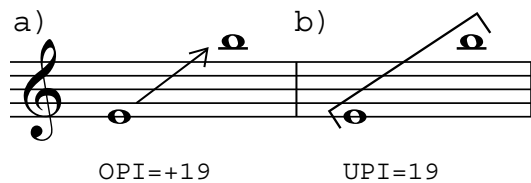

Fig. 2.4. Pitch Intervals

Motion from one pitch class to the next that takes into account the direction traversed is an *ordered pitch-class interval* (OPCI) (fig. 2.5a). In turn, an *unordered pitch-class interval* (UPCI) is a measurement of the shortest distance between two pitch classes (fig. 2.5b).

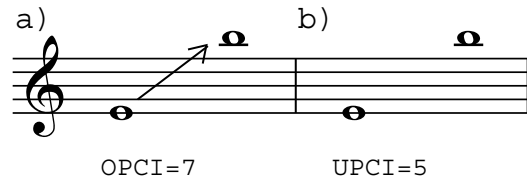

Fig. 2.5. Pitch-Class Intervals

In order to help facilitate better visualization of spatial relationships between pitch classes, theorist Joseph Straus illustrates in his introductory post-tonal textbook the twelve pitch classes plotted on a clockface.⁶¹ Upward transit from one pitch class to the next is depicted by clockwise movement around the clockface and downward progression by counterclockwise motion. For example, a shift from C# to A results in an ascent of eight semitones or a descent of four semitones (fig. 2.6a). Unordered pitch-class intervals are easily figured by locating the pitch classes on the clockface and counting the semitones in the smaller circumferential segment (fig. 2.6b).

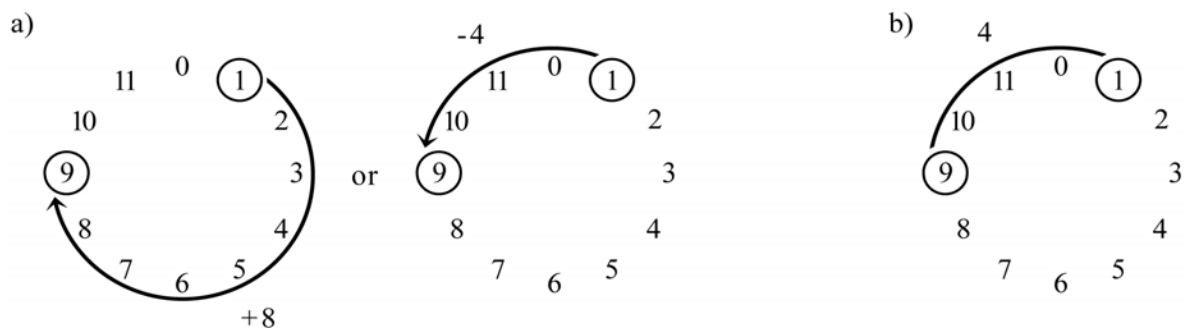

Fig. 2.6. Clockface

Division of the clockface into two equivalent halves reveals the largest unordered pitch-class

⁶¹Joseph N. Straus, *Introduction to Post-Tonal Theory* (Englewood Cliffs, N.J.: Prentice Hall, 1990), 4.

interval, which is comprised of six semitones. As there are only six unordered pitch-class intervals that epitomize the sound essence of various intervals and their octave counterparts, each one is referred to as an *interval class* (IC). An *interval vector* is the name given to a consecutive listing with no intervening spaces of the number of times each interval class recurs throughout a given sonority from smallest to largest (fig. 2.7).

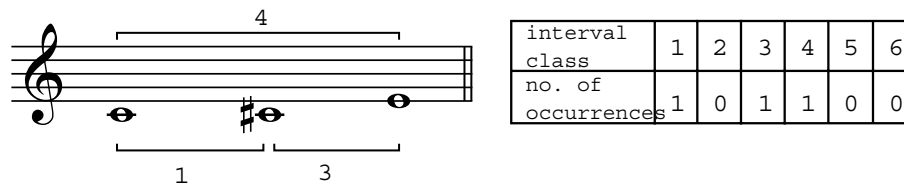

Fig. 2.7. Interval Vector

Along with dyads, *pitch-class sets*, or unordered groups of three to nine pitch classes, characterize the sound quality of post-tonal musical compositions. The unique attributes of a given set are created by its adjacent interval classes. In order to identify the pitch-class set to which a group of pitches belongs, the pitches are rewritten in their *normal form* as pitch classes ascending within the octave in the closest possible registral proximity to one another. One can determine the most compact way to write the pitch classes ascending within the octave by first comparing the outermost ordered pitch-class intervals of all the potential orderings (fig. 2.8a). Should the smallest interval result in a tie between the pitch class successions, the intervals created by the first pitch class and the next-to-last pitch class are then compared. This systematic inward progression from the last pitch class of the orderings results in the breaking of intervallic ties (fig. 2.8b). The pitch classes of the ensuing normal form are separated by commas and are enclosed in brackets (fig. 2.8c).

a)

b)

c)

[1, 3, 5, 9]

Fig. 2.8. Normal Form

Pitch-class sets that differ in pitch class content, but have the same underlying intervallic content, contribute to unity throughout a musical composition. Two basic operations transfer such pitch-class sets into a single *prime form*, in which the set is reconstructed beginning with pitch class zero from the intervals of the normal form. The building of a prime form begins at the smaller interval or grouping of intervals within the normal form and ends with the larger interval or intervallic grouping. Unlike the normal form layout of pitch classes, the pitch classes of a prime form are not separated by commas and are enclosed in parentheses. The addition of a prescribed pitch-class interval to each pitch class results in the *transposition* (T_n) of a pitch-class set (fig. 2.9).

$$\begin{array}{r}
 T_6 \text{ of } [6, 7, 10]: \\
 6 \ 7 \ 10 \quad [6, 7, 10] \rightarrow \\
 + \frac{6 \ 6 \ 6}{0 \ 1 \ 4} \quad (014)
 \end{array}$$

Fig. 2.9. Transposition of a Pitch-Class Set

Inversion (T_nI) of a pitch-class set is a two-step process figured by first subtracting each pitch class from twelve to produce the complementary pitch classes. Subtraction of pitch class zero from twelve, however, does not yield a different pitch class. Because there are only twelve pitch classes, the addition or subtraction of twelve simply renders the identical pitch class. Following inversion, the pitch-class set is then transposed by means of a given pitch-class interval (fig. 2.10).

$$\begin{array}{l}
 T_6I \text{ of } [0, 5, 6]: \\
 (12 - 0) + 6 = 6 \\
 (12 - 5) + 6 = 1 \\
 (12 - 6) + 6 = 0 \\
 [0, 5, 6] \rightarrow (016)
 \end{array}$$

Fig. 2.10. Inversion of a Pitch-Class Set

The resultant prime form is identified as a *set class*, which can be classified according to the list generated by Allen Forte, the codifier of set theory. A set class is represented as a pair of numbers separated by a dash, with the first number disclosing the number of pitch classes in the set, and the second number its location on Forte's set-class list (e.g., 4-3). A characterizing feature of each set class is its *degree of symmetry* indicating the number of times it can be *mapped*, or transformed, onto itself by means of transposition or inversion. A pair of numbers separated by a comma denotes the degree of symmetry for a given set: the number of transpositional and inversional levels respectively.

There are several relationships between sets that create post-tonal musical associations.

Z-related sets have identical interval-class content, but differing prime forms (fig. 2.11).



	
4-Z29 (0137)	4-Z15 (0146)
interval vector 111111	interval vector 111111

Fig. 2.11. Z-Related Sets

Every set has a corresponding *complement* composed of the pitch classes not included in the original set. With a single exception, the larger set contains a proportionally greater number of each interval class equal to the difference in the number of pitch classes between the larger and smaller sets. Due to its self-inversional nature, interval class six occurs in the larger set at half this rate (fig. 2.12).

	
3-3 (014)	9-3 (012345689)
interval vector 101100	interval vector (012345689)

Fig. 2.12. Complementary Sets

In addition to literal complements, complement-related sets have a strong correlation effected by the similarity of their interval vectors. Large numbers of *subsets* can conceivably play a significant role in shaping a musical composition. The select subsets highlighted in a musical texture, as well as the potential presence of the *superset* to which the subsets belong, provide additional means of compositional unity. Possible set relations particular to dodecaphonic works might include the *combinatorial* juxtaposition of a set with a transposed or inverted form of itself or its complement in creating an *aggregate*, or a grouping of the twelve pitch classes (fig. 2.13).

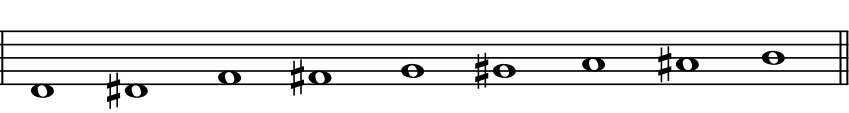
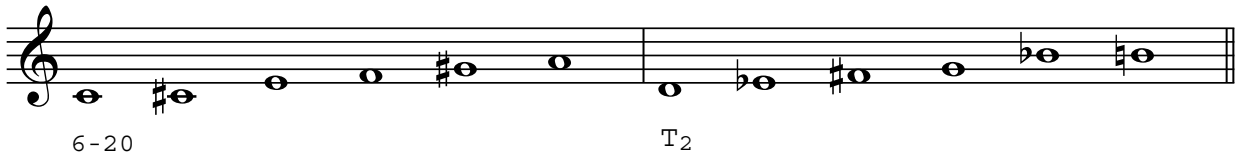

Fig. 2.13. Combinatorial Sets

A *twelve-tone row* is an ordered succession of the twelve pitch classes that recur pervasively throughout a composition in the original sequence, or as permutations of this sequence (fig. 2.14). Reversal of the original series, or the *prime* (P) ordering, results in a *retrograde* (R) ordering of the row. As with pitch-class sets, *inversion* (I) of the prime row is produced by calculating the complement of each pitch class. *Retrograde-inversion* (RI) is the reversal of the inverted form of the row.

P:	0	3	5	8	2	10	1	6	4	9	7	11
R:	11	7	9	4	6	1	10	2	8	5	3	0
I:	0	9	7	4	10	2	11	6	8	3	5	1
RI:	1	5	3	8	6	11	2	10	4	7	9	0

Fig. 2.14. Row Forms

Transposition of the row forms alters the order in which the pitch classes sound, but retains their ordered pitch-class intervals and set content. Subdivisions of the row, particularly those of trichords, tetrachords, and hexachords, along with the intervals created by adjacent pitch classes within the row, lend themselves to formulating the unique sound qualities of a musical composition. In addition, non-contiguous pitch alignments and their relationship to the original partitions of the row merit close examination.

Bernard's Spatial Arena

In order to study the music of Edgard Varèse, Jonathan Bernard originally conceived of a

spatial environment in which musical entities transform into related forms.⁶² An examination of the vast array of sonorities characteristically found in this composer's music would soon yield an unwieldy amount of empirical data. Instead, Bernard's unearthing of the underlying processes by which entities of sound metamorphose into related forms reveals musical textures controlled by a surprisingly limited number of units. As is the case in Varèse's oeuvre, the musical fabric of Op. 18 appears at first to be deceptively complex. However, utilization of Bernard's method will uncover the fact that a limited number of pitch intervals and their related forms pervade the texture of Webern's songs.

Bernard's analytical approach is based on pitch interval sizes and distances between sounds.⁶³ Harmonic intervals of a group of pitches are measured in registral proximity to one another. There are two different ways to measure a linear progression of pitches. Each pitch can be arranged in a vertical array wherein the pitches are posited in registral proximity to one another regardless of the order in which they occur. From this vertical continuum, intervallic pitch measurements are taken (fig. 2.15a). Pitch intervals can also be measured consecutively in a linear progression of pitches (fig. 2.15b).

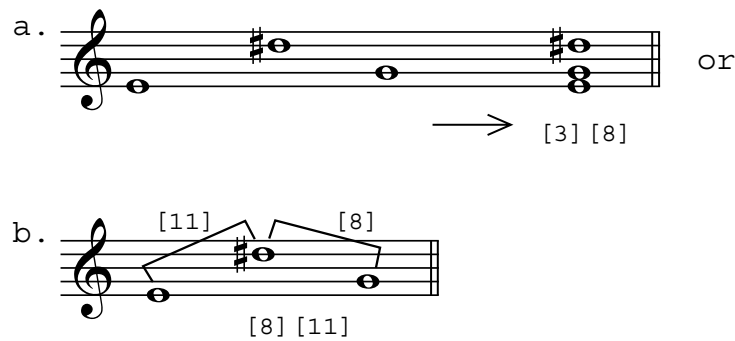

Fig. 2.15. Pitch-Interval Measurement of a Linear Progression

Mirror symmetry denotes a sonority comprised of several pitches in which the intervallic makeup of the registral group forms a palindrome (fig. 2.16a). In contrast, *parallel symmetry* refers to a group of pitches that can be split into two or more segments consisting of identical intervallic

⁶²Jonathan Bernard, *The Music of Edgard Varèse* (New Haven: Yale University Press, 1987), 39-127.

⁶³Numbers in square brackets will be used to indicate intervallic measurements between pitches.

measurements from the lowest to the highest pitch (fig. 2.16b).

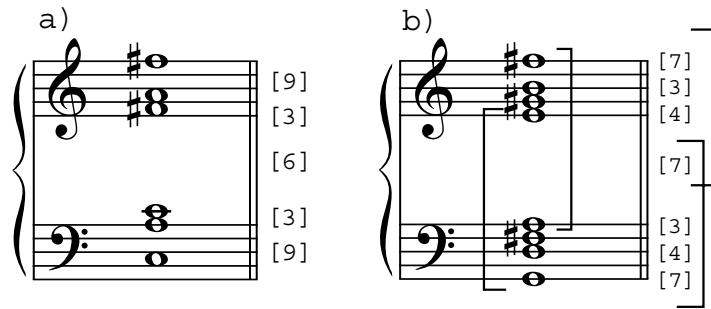

Fig. 2.16. Mirror and Parallel Symmetry

Bernard expounds several means by which musical entities traverse throughout space. *Projection* occurs when a sonority is transferred to a different registral location. Although the interval size of the outermost pitches is preserved during this process, the inner contents are not necessarily retained (fig. 2.17).

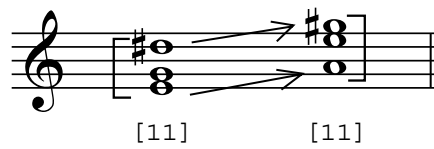

Fig. 2.17. Projection

Rotation takes place if the inner and outer constituents of a musical entity are preserved, but rotated 180 degrees during the course of projection (fig. 2.18).

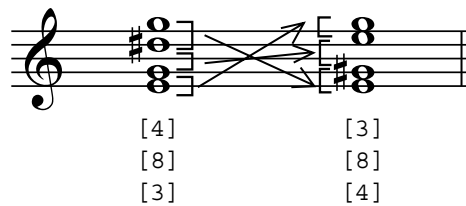

Fig. 2.18. Rotation

The equidistant extension of a pitch group's outer boundaries is defined as *expansion* (fig. 2.19a). In turn, *contraction* is the equidistant abridgement of these boundaries (fig. 2.19b).

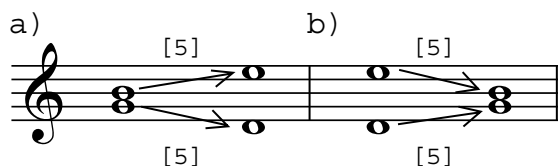

Fig. 2.19. Expansion and Contraction

The pitch-interval content of two unequal adjacent intervals, or *trichords*, and their related forms are used to measure the intervallic constitution of a composition.⁶⁴ The *basic form* (fig. 2.20a) of a trichord can evolve into three related forms called *first-order derivatives*. *Unfolding* occurs when the central pitch of a trichord pivots around either of the outer pitches, thus relocating to a new position (fig. 2.20b). In contrast, *infolding* results from the outermost pitch of the smaller interval pivoting around the central pitch into the spatial realm of the larger interval (fig. 2.20c). The distance between the moving pitch and the pitch acting as a pivot is maintained during these transferences. A *constellation* is a basic form and its collection of first-order derivatives.

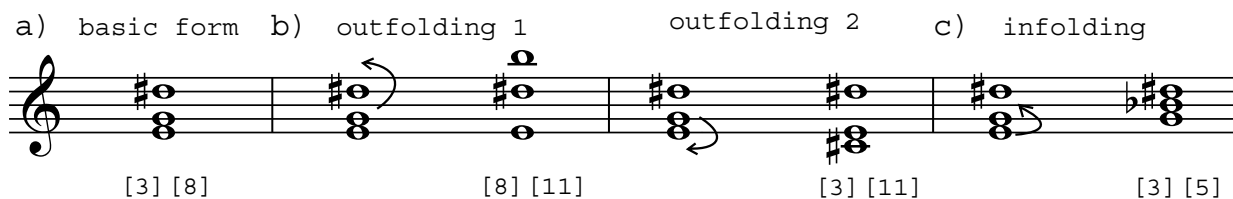

Fig. 2.20. Constellation

⁶⁴Bernard's trichords are not to be confused with Allen Forte's trichordal set classes which are measurements of interval-class content.

Two identical adjacent intervals can be perceived either as the projection of a single interval or as a trichord. The infolding of such a trichord, however, results in the formation of a dyad. Two basic forms that have in common a first-order derivative are *second-order derivatives* of one another.

In order to illustrate Bernard's theoretical spatial environment, I have placed the pitches onto a graph where they are identified by means of integer notation. The pitches are arranged in relative registral distance from one another, their exact frequency indicated by C calibrations on the vertical axis. Each pitch is plotted on the graph from left to right in the order in which it sounds. The exact durational length of the pitches is not represented on the graph.

Marvin and Laprade's Contour Segments

Elizabeth West Marvin and Paul A. Laprade developed their contour theory⁶⁵ in response to psychologists' findings that listeners associate melodies with similar contours despite variances in intervallic makeup.⁶⁶ The theorists extend Robert Morris's concept of contour space,⁶⁷ a musical realm in which pitches are organized in terms of relative registral location, in defining three- to six-pitch contour segments and their related forms. A *contour segment* is formed by numbering the pitches of a melody from the lowest to the highest, with zero being assigned to the lowest pitch. This numeration of the pitches extends to (n-1) where n equals the total number of pitches. The pitches are then removed from their musical context and situated as *contour pitches* in relative distance to one another with a connecting line representing the

⁶⁵Elizabeth West Marvin and Paul A. Laprade, "Relating Musical Contours: Extensions of a Theory for Contour," *Journal of Music Theory* 31, no. 2 (fall 1987), 225-67.

⁶⁶Marvin and Laprade cite the work of the following psychologists in backing up the premise of their contour theory: Diana Deutsch, "The Processing of Pitch Combinations," *The Psychology of Music* (New York: Academic Press, 1982), 277-89; W. J. Dowling and A. W. Hollombe, "The Perception of Melodies Distorted By Splitting Into Several Octaves: Effects of Increasing Proximity and Melodic Contour," *Perception and Psychophysics* 21 (1977): 60-4; W. L. Idson and D. W. Massaro, "A Bidimensional Model of Pitch in the Recognition of Melodies," *Perception and Psychophysics* 24 (1978): 551-65; W. J. Downing and D. S. Fujitani, "Contour, Interval, and Pitch Recognition in Memory for Melodies," *The Journal of the Acoustical Society of America* 49 (1971): 524-31. West and Laprade, "Relating Musical Contours: Extensions of a Theory for Contour," 225 n. 3.

⁶⁷The authors refer to Morris's definition of "contour space" which is outlined in the glossary of the following text: Robert Morris, *Composition with Pitch Classes: A Theory of Compositional Design* (New Haven: Yale University Press, 1987), 340. West and Laprade, "Relating Musical Contours: Extensions of a Theory for Contour," 226 n. 10.

contour of the melody (fig. 2.21).

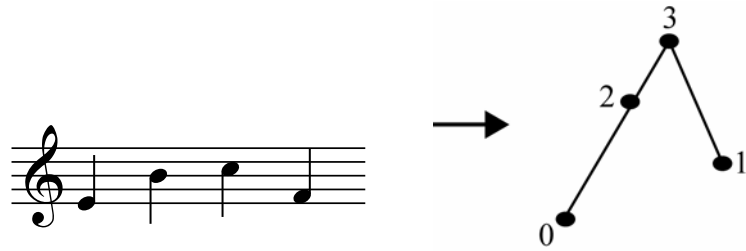

Fig. 2.21. Contour Segment

The *prime form* (P) of a contour segment (fig. 2.22a) can be transformed into related forms by means of several operations. Reversal of the prime form (R) yields the *retrograde* of the original contour (fig. 2.22b). *Inversion* of the prime form (I) is calculated by subtracting (n-1) from each contour pitch (fig. 2.22c). *Retrograde inversion* (RI) results from the reversal of an inverted contour (fig. 2.22d). It is important to note that contour segments can also be divided into and discussed in terms of *contour subsegments*.

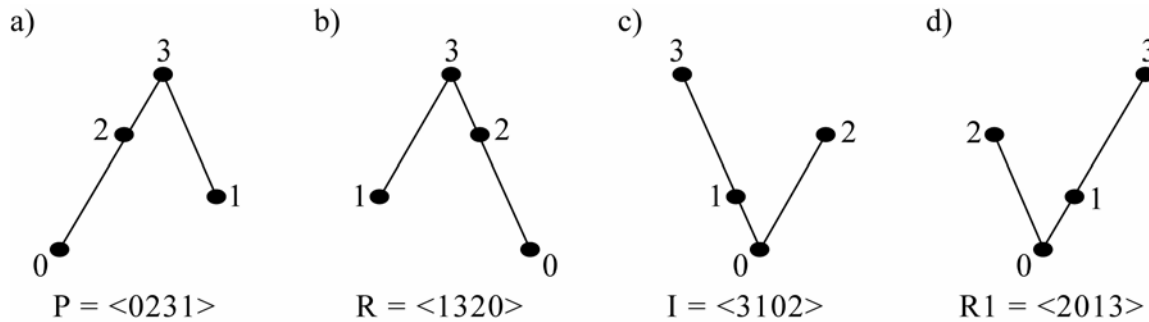

Fig. 2.22. Related Forms of a Contour Segment

Morris's Contour Reduction Algorithm

Robert Morris extended the notion of contour space in creating his *contour reduction*

*algorithm*⁶⁸ based on the Gestalt-psychology idea regarding boundary salience.⁶⁹ This analytical tool will be used to highlight the outer radii of larger contours containing seven or more contour pitches. The purpose of the algorithm is to weed out pitches in a series of steps from which the prime form of the original contour emerges. The first step in applying the contour reduction algorithm is to plot the pitches of a melody as points in relative registral distance to one another (fig. 2.23a). Then, maximum and minimum pitches are flagged according to a simple set of procedures. Given a series of three adjacent pitches, the second pitch is defined as a *maximum pitch* if it is higher than or equal to the others. Conversely, the second pitch is designated as a *minimum pitch* if it is lower than or equal to the other two pitches. The first and last pitches of a contour are considered to be both maxima and minima, thus receiving two flags per pitch (2.23b).

The process of designating the maxima and minima of a melody begins with the first set of three pitches and continues sequentially with the second, third, and fourth pitches up to the final three. Pitches that remain unflagged following this process are deleted. Should adjacent repeated maxima or minima result from the pruning, either of the repeated pitches is deleted unless one of them is the first or last pitch of the contour. In this case, the beginning or ending pitch takes precedence and the other pitch is weeded out. Beginning and ending pitches that are both equal and adjacent remain flagged (fig. 2.23c). It is necessary to repeat the sequence of steps for pruning pitches until the *prime* form of the contour is arrived at (2.23d). The number of stages necessary for assigning minimum and maximum pitches is referred to as the *depth* of a contour.

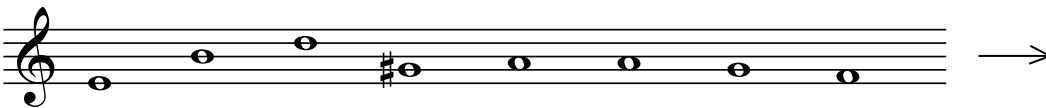

Fig. 2.23 Contour Reduction Algorithm

⁶⁸Robert D. Morris, "New Directions in the Theory and Analysis of Musical Contour," *Music Theory Spectrum* 15, no. 2 (fall 1993): 205-28.

⁶⁹*Ibid.*, 215.

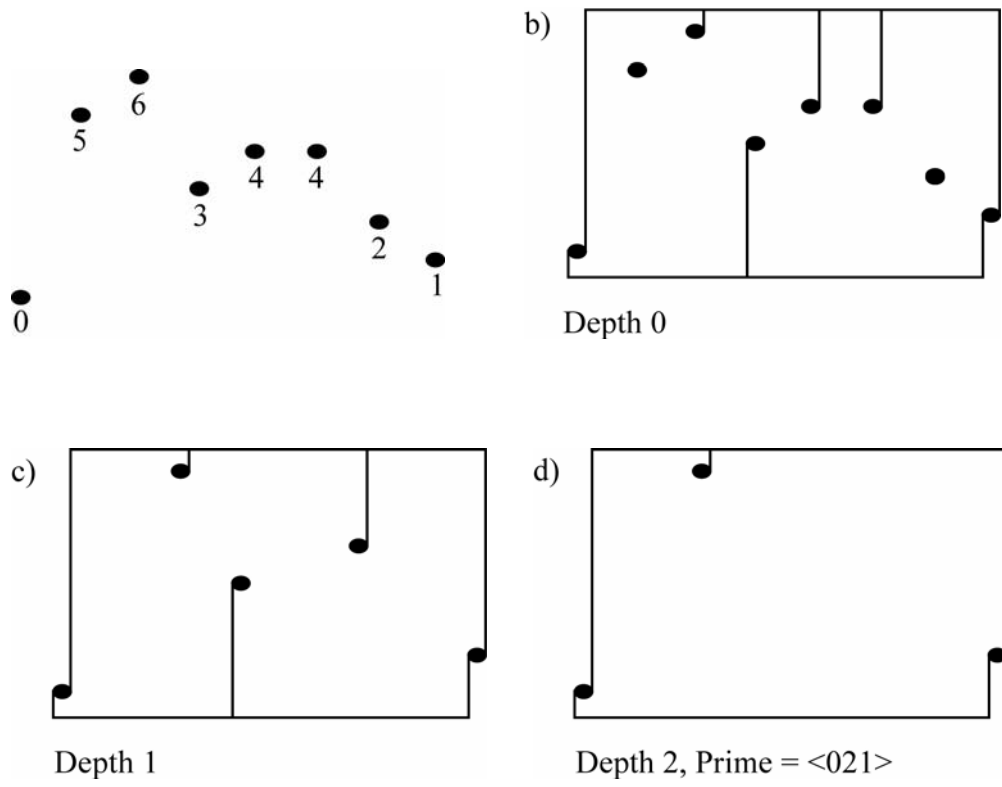

Fig. 2.23. Contour Reduction Algorithm (continued)

CHAPTER THREE

OP. 18, NO. 1 (“SCHATZERL KLEIN”): A LOVER’S VISION

Webern set music to the folkloristic poem “Schatzerl klein” (Little Sweetheart) in composing the first song of Op. 18. Rosegger’s cheerful “Schatzerl klein” is a simple poem whose pure utterances of joy are expressed through unaffected, dialectic language and the straightforward regularity of its line schema. The love poem is divided into three stanzas, each made up of four lines. In the first stanza, the speaker of the poem reassures his beloved of his commitment to her by joyfully anticipating that they will be married by the year’s end. He imagines the scene of their pending nuptials in the second stanza, a vision in which the priest’s sanctification of their union is accompanied by the blooming of rosemary. Rosegger associated the flower with virginity in accordance with its longstanding symbolic meaning in German literature.⁷⁰ Numerous German literary sources cite rosemary as a flower worn by virgin brides, frequently interwoven along with myrtle in a bridal wreath. In the third stanza of the poem, the speaker foresees a life of marital happiness in an idyllic setting framed with flowers whose presence conjures up traditional symbolic connotations. The recurring motif of blooming rosemary reappears, this time along with a bouquet of myrtle. In addition to the myrtle’s bridal associations in conjunction with rosemary, the scent of myrtle has been frequently portrayed in German literature as an aphrodisiac affiliated with Venus, the goddess of love. Within the couple’s home, a carnation stock blooms, its fragrance traditionally believed to be a combatant against sickness and demonic forces.⁷¹

⁷⁰Anne Shreffler points out Rosegger’s description of rosemary as a flower worn in garlands by young girls on “Jungfrautag” (the day of the Virgin) in “Der Hinterschöpp” of *Buch der Novellen I*. Anne Shreffler, “Webern’s Twelve-Tone Composition,” 331.

⁷¹See Jacob Grimm and Wilhelm Grimm’s etymological *Deutsches Wörterbuch* for the symbolic meanings associated with rosemary, myrtle, and carnation stock, which are corroborated with numerous literary excerpts. A detailed history of the superstitious connotations linked to carnation stock (Nelkenstock) is outlined in the sixth volume of Hanns Bächtold-Stäubli’s *Handwörterbuch des deutschen Aberglaubens*. The word “Nagerl,” an Austrian dialectic version of “Nagel,” appears more commonly in its diminutive form “Näglein, a word interchangeable with

The trochaic metrical pattern applied consistently to the three- and five-foot lines throughout the poem provides a pleasing lilt that suggests the movement of the couple on the unimpeded path lying before them toward the fulfillment of their love for one another. Each line concludes with masculine endings that create a slight pause between the lines, reflecting the slow, steady progression of the relationship between the speaker and his beloved. The metrical accents are clearly articulated by the corresponding durational lengths of the vocal pitches. The duration of the metrically strong syllables are either longer or equal to those of the weak syllables (fig. 3.1).

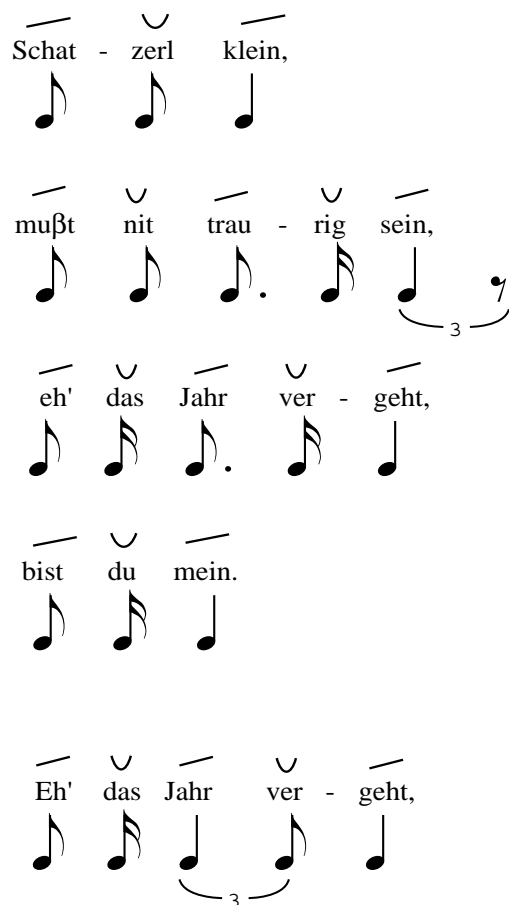

Fig. 3.1 Durational Lengths of the Vocal Pitches

“Nelke,” the modern German word for carnation.

grünt der Ros - ma - rin,
sagt der Phar - rer laut:
Nehmts euch hin.

Grünt der Ros - ma - rin,
grünt der Myr - ten - strauß
und der Na - gerl - stock
blüht im Haus.

Fig. 3.1. Durational Lengths of the Vocal Pitches (continued)

The speaker's optimistic message to his beloved is contained within an irregular rhyme scheme containing two repeating lines, and the imperfect assonant rhyming of "laut" and "-straus." His ingenuous manner in addressing her is thus reflected in the simple, seemingly artless nature of the poetic structure (fig. 3.2).

“Schatzerl klein”		“Little Sweetheart”
Schatz-erl klein,	A	Little sweetheart,
mußt nit trau-rig sein,	A	Don’t be sad.
eh’ das Jahr ver-geht,	B	Before the year passes by,
bist du mein.	A	You will be mine.
Eh’ das Jahr ver-geht,	B	Before the year passes by,
grünt der Ros-ma-rin,	C	The rosemary will be blooming,
sagt der Pfar-rer laut:	D	And the priest will say loudly:
Nehmts euch hin.	C	“Take one another.”
Grünt der Ros-ma-rin,	C	The rosemary will be blooming,
grünt der Myr-ten-strauß	D	the myrtle bouquet will be blooming.
und der Na-gerl-stock	E	and the carnation stock
blüht im Haus.	D	will be blooming in the house.

Fig. 3.2. “Schatzerl klein,” Rhyme Schema and English Translation⁷²

The straightforward message of “Schatzerl klein” is expressed musically by twenty-two adjacent statements of a single prime row. Unlike Webern’s linear row statements, which he used exclusively in his compositions beginning with Op. 18, no. 3, the row pitches of “Schatzerl klein” are positioned in harmonic relation to one another among all three parts. Examination of the row intervals, those built from adjacent row pitch classes as well as non-adjacent row pitch classes separated by a single row member, reveals that a limited number of them characterize the sound of the row (fig. 3.3). I have included “around-the-corner” intervals in my row chart as they are exploited by Webern throughout “Schatzerl klein.”

A quarter of the row intervals are members of IC 1, the distinctively piquant sound that figures prominently throughout “Schatzerl klein” in the melodic intervals of the voice and clarinet, as well as in the harmonic intervals of the guitar chords. In addition, UPCI 1 sounds frequently in the vertical sonorities, sound structures formed by the simultaneous merging of individual voices. Because of the harmonic row pitch layout, UPCI 1 is constructed in the

⁷²Translation by the author.

melody of the voice primarily with non-adjacent row members, many removed by more than one pitch class. In contrast, UPCI 1 recurs in the clarinet part and vertical arrays as a mixture of

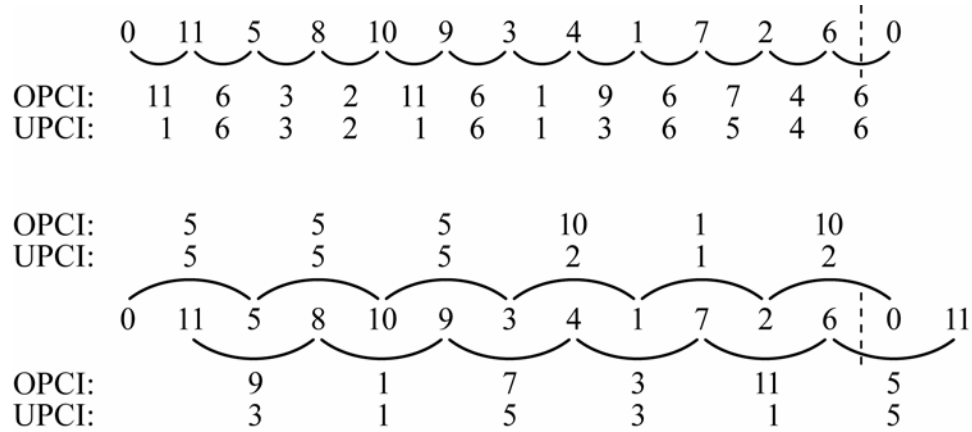

Fig. 3.3. “Schatzerl klein” Row Intervals

sonorities built in three ways: as adjacent row pitch classes, row pitch classes separated by one row member, and pitch classes further removed from one another among the row. Row adjacencies of UPCI 1 are exploited most frequently as UPI 11 in the outermost intervals of the three-note harmonic guitar chords.

UPCI 5 makes fleeting references to the tonal language of the traditional *Volkslied* as UPI 5 at the beginning of “Schatzerl klein” before sounding often throughout the harmonic chords of the guitar along with UPI 6, creating a singular, post-tonal sound. The pervasive recurrence of this particular chord provides a soothingly repetitive accompaniment in the style of the *Volkslied*. Surprisingly, the interval that plays such an important role throughout the song appears only once as a row adjacency. UPCI 5 occurs five times, however, as an interval built with non-adjacent row pitch classes separated by a single row pitch class. These neighboring row intervals are exploited frequently in the harmonic guitar accompaniment, along with the periodic surfacing of UPCI 5 formed both by distantly-removed row pitch classes and adjacent row pitch classes. The sound of UPCI 5 is further reinforced in the vertical sonorities as intervals built primarily from non-adjacent row members, those removed by a single row pitch class and those more distantly situated. Above the predictable guitar accompaniment, UPI 5 recurs sporadically, but

significantly, by the voice and clarinet, a topic that will be fleshed out in greater detail at a latter point in my discussion.

The already-mentioned IC 6 sounds four out of twelve times by adjacent pitch classes of the row. Its preponderant recurrence throughout the guitar accompaniment as UPI 6 is created primarily by these contiguous row pitch classes. Row adjacencies of UPCI 6, sounding both as UPI 6 and as larger compound intervals, are also featured throughout the vertical sonorities of “Schatzerl klein.” The tension-laden sound of UPCI 6, an interval formed primarily by neighboring row tones, complements the pervasive sound of UPCI 1 in the melodic lines of the voice and the clarinet. Other row intervals will not be elaborated on at this point of my discussion. Instead, additional intervals that capture the sound of “Schatzerl klein” will be considered as my analytical perspective unfolds.

Webern’s heavy emphasis on ICs 1, 5, and 6 results in a limited number of sets recurring throughout the Op. 18, no. 1 row. Trichord 3-5 sounds five out of twelve times due to repeated adjacencies of UPCIs 1 and 6.⁷³ This set is utilized heavily throughout the guitar accompaniment of “Schatzerl klein,” creating a predictable accompaniment pattern resembling that of the traditional *Volkslied*. The vertical sonorities formed by the guitar, along with one or both of the melodic parts, are also saturated with 3-5 occurrences. In addition, the set is articulated by the voice and clarinet at significant musical junctures throughout “Schatzerl klein.” Set 3-10, the only other repeated trichordal set of the row, surfaces only sporadically throughout the guitar accompaniment, albeit more frequently in the vertical sonorities. The set is formed only once in the vocal line by non-adjacent row pitch classes and does not occur at all in the clarinet part. Webern chose instead to exploit non-adjacent row intervals in building numerous sets that sound only once throughout the row.

Additional noteworthy set properties characteristic of the “Schatzerl klein” row are displayed throughout the larger set imbrications, namely as repeated or Z-related sets. Although recurring sets do not predominate the tetrachordal row imbrications, 4-13, 4-9, and 4-Z29 each occur twice throughout the row. Tetrachord 4-9 has a unique (2,2) degree of symmetry, yielding six distinct pitch-class sets. Although Webern utilizes each possibility throughout “Schatzerl klein,” pitch-class sets [3, 4, 9, 10] and [5, 6, 11, 0] pervade the song’s musical texture. With the

⁷³My discussion of the Op. 18, no. 1 set imbrications includes “around-the-corner” sets.

exception of its Z-correspondent, the all-interval content of 4-Z29 is unique to the tetrachordal sets, a characteristic sound that plays a pivotal role in underscoring the transitional moments throughout the “Schatzerl klein” text. Pentachords 5-Z36 and 5-Z12 sound once throughout the “Schatzerl klein” row, a pair of Z-related sets with identical IC content. Z-related sets are exploited most frequently throughout the row as hexachordal pairs: 6-Z36/6-Z3, 6-Z6/6-Z38, and 6-Z41/6-Z12, both sets of the final pair occurring twice in the row. In addition, the remaining hexachordal imbrications 6-18 and 6-30 each sound two times throughout the row, contributing to its uniform sound quality. As with the row intervals, Webern’s exploitation of sets formed by neighboring row pitches, as well as recurring sets built from non-adjacent row members, will be examined in greater detail throughout my set-class discussion.

Musicologist Joachim Noller proposes that the repeated perfect fourth sung by the voice at the beginning of Op. 18 as the speaker addresses his sweetheart (m. 2, bts. 1-2) hints at a possible continuation of familiar pentatonic musical material characteristic of a *Volkslied*.⁷⁴ Following an additional ascent of a perfect fourth by the voice, however, he notes that the musical material moves rapidly away from this initial tonal reference. I expand on Noller’s observation by discussing the infrequent, but strategic, occurrences of perfect fourths among the voice, clarinet, and guitar parts, all three of which draw attention to the thematic material of each stanza.

Perfect fourth intervals are featured prominently throughout the first stanza of “Schatzerl klein.” The initial vocal statement of the perfect fourths is foreshadowed melodically by the clarinet and the guitar in the brief instrumental introduction (m. 1). Similar to that of the voice, the perfect fourth of the clarinet is immediately followed by intervallic progressions that depart from the *Volkslied*’s tonal roots. In contrast to the intervals executed by the voice and clarinet, the perfect fourth is played by the guitar in several different guises throughout the first part of the song: in its two initial melodic fragments, the second of which also contains a harmonic fourth (mm. 1-2) as a pair of stacked melodic intervals (m. 3, bt. 1), and in the short, two-note bass lines (m. 3, bts. 2-m. 4, bt. 1). The extreme brevity of the guitar’s phrases, marked by frequent occurrences of rests, further enhances the reiteration of the fourths. The perfect fourth is not entirely forsaken by the voice in the first stanza, sounding as its final descending interval when

⁷⁴Joachim Noller, “Das Dodecaphone Volkslied,” 141.

the speaker tells his beloved that he will marry her by the year's end (mm. 4-5). The guitar follows with a full-sounding five-note chord in which the upper three intervals consist of stacked perfect fourths, the only harmonic guitar chord built from combined fourths appearing in "Schatzerl klein" (m. 5, bt. 2).

Salient use of the perfect fourth is not completely abandoned after the end of the first stanza. The five-note chord sounds again beneath the word "vergeht" (passes by), a reminder of the events that will take place before the passing of the year (m. 6, bt. 2). It recurs in the second stanza of the vocal line when the speaker of the poem joyfully anticipates the pronouncement by the priest of marital union with his beloved (m. 7, bt. 3). The interval is foreshadowed by the harmonic fourth of the guitar, a sparse, two-note chord highlighted by its placement between two rests (m. 7, bt.3). A perfect fourth sounds again in the vocal part of the third stanza just before the word "Nagerlstock" (carnation stock), the flower whose blooming symbolizes impending domestic tranquility and well-being (m.11, bt.3). Once more, the fourth is anticipated harmonically by the guitar, this time with the identical pitch classes that will be subsequently sung by the voice (m. 11, bt. 2).

The perfect fourth thus takes on a small, yet significant role in gently marking key phrases that indicate the themes of each stanza: those of the lover's invocation to his beloved, eager anticipation of his impending nuptials, and his vision of domestic bliss. The periodic surfacing of this interval in "Schatzerl klein" serves as a vestigial link to the rich musical tradition of the *Volkslied*. The recurrence of the perfect fourths in the above-mentioned examples is further emphasized by the musical context in which they sound. Significantly, with the exception of the single descending fourth in mm. 4-5, the phrases in which the ascending perfect fourths appear in the vocal line are the only ones articulated with *staccato* markings. Moreover, the perfect fourth in the second stanza (m. 7, bt. 3) recurs with the identical pitches used in m. 2 at the word "mußt." Throughout "Schatzerl klein," the guitar part is rife with the sound of perfect fourths, more appropriately referred to as UPI 5 because they are articulated primarily in combination with other pitches within a post-tonal context. Occurrences of perfect fourths as separate entities, however, appear only in proximity to the perfect fourths of the voice.

The perfect fourth cluster that characterizes the beginning of the vocal line evolves into an amalgamation of different intervals. The guitar's opening gesture in the instrumental

introduction, which is built from the first three row pitch classes, is a telling indication of the intervallic metamorphosis that will take place throughout “Schatzerl klein.” Its initial UPI 17, a compound form of OPI 5, joins with the harmonic UPI 6 at the second melodic pitch in forming trichord [6][17]. Then, UPI 6 merges with B₄, creating trichord [5][6], a second-order derivative of [6][17] that will come to predominate the guitar accompaniment in the second and third stanzas (m. 1). The sound of trichord [5][6] is further reinforced by the clarinet’s [5][11] unfolding, a melody whose final pitch overlaps with the beginning of the vocal line (mm. 1-2) (fig. 3.4).

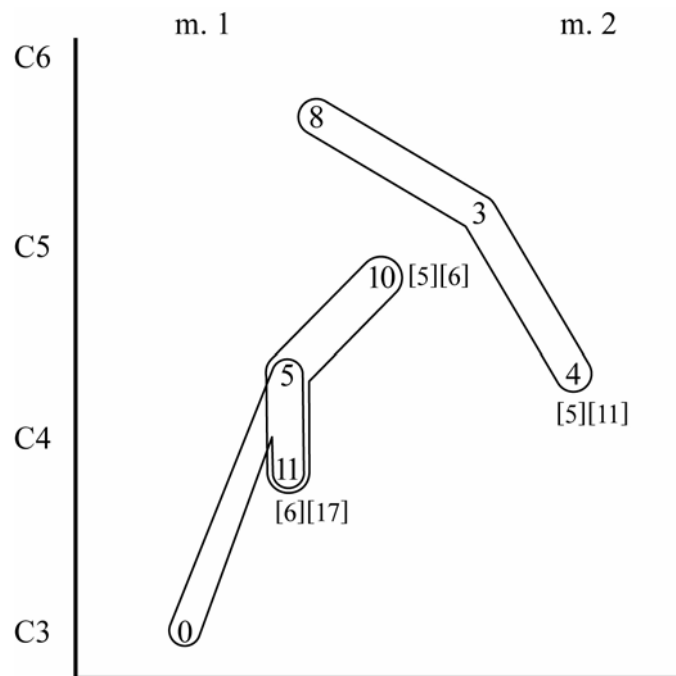

Fig. 3.4. Instrumental Introduction, mm. 1-2

Beneath the repeated perfect fourths at the phrase “Schatzerl klein” (little sweetheart), the guitar articulates [5][5], a trichord based on the projection of UPI 5. Its final melodic OPI +5 ascent coincides with the OPI -5 vocal descent, an intervallic contraction that accompanies the word “klein” (little) (m. 2, bts. 1-2). The sparse intervallic content of the voice and guitar parts appropriately coincides with the speaker’s address to his sweetheart. This aphoristic musical

gesture suggests richer musical material to follow, just as the speaker's invocation implies that his romantic relationship will be defined throughout the course of the song. Following the modest intervallic opening of "Schatzerl klein," the voice and clarinet then display expanded UPCI 1 versions, a sonority first presented by the guitar in its most compact OPI -1 form. This descending OPI modestly concludes the guitar's introductory phrase as a hushed, slowing figure (m. 1). The emergence of contrastingly large UPCI 1s from the unassuming opening underscores the beloved's distress as the speaker implores her not to be sad (mußt nit traurig sein) (mm. 2-3). This tension-filled sound emanates from successive vocal statements of UPI 13, OPIs -13 and +13 respectively, separated by an intervening OPI -6. The clarinet articulates a similar musical pattern with a sharply ascending OPI +25 on the last two eighth notes of measure two followed by OPI +11, an intervallic pair also interpolated with OPI -6 (fig. 3.5).

UPI 1 is further realized by a series of rapid vocal trichords formed at the phrase "eh' das Jahr vergeht" (before the year passes by), during which the speaker anticipates future matrimony with his beloved (mm. 3-4). Trichord [4][11] transforms into [11][14] followed by [3][14], two [3][11] outfoldings, succeeded by a statement of [3][11] itself. The IC essence of the basic [3][11] form is preserved in the descending clarinet lines that accompany the anticipatory phrase: in measure three as OPIs -9 and -11 and in measure four as OPIs -13 and -3. In addition, the [3][11] constellation is foreshadowed by the instrumental [11][14], a vertical trichord that marks the beginning of the phrase. This trichord is formed by the guitar's UPI 11 chord sounding beneath the sustained B₅ of the clarinet (m. 3, bt. 3). As with the guitar's opening phrase, the vocal line concludes with a softening OPI -1, a figure whose *ritardando* tempo is maintained throughout the subsequent ending line of the first stanza (m. 4, bt. 2) (fig. 3.6).

Trichord [5][6] is intermittently stated throughout the first stanza, a sonority that will inundate the second and third stanzas as the speaker elaborates on a vision of future happiness with his beloved (fig. 3.7). In measure three, a pithy guitar figure composed of stacked OPI +5s separated by UPI 6 first hints at the trichordal [5][6] influx. The second UPI 6 coincides with the clarinet's B₄ in forming a vertical [5][6] trichord. A consecutive [5][6] trichord sounds when the sustained melodic pitches of the guitar and clarinet overlap with the voice's F₅ (m. 3, bt. 1). Trichord [5][6] is projected by the guitar beneath the anticipatory phrase "eh' das Jahr vergeht,

bist du mein” (before the year passes by, you will be mine) (m. 3, bt. 2-m. 5, bt. 1). First, trichord [5][11], an unfolding of [5][6], is articulated at the beginning of the phrase (m.3, bts. 2-3). Then, trichord [5][6] sounds as a harmonic chord built from adjacent row members (m. 4, bt. 1). The outermost interval of this chord is projected to several different registral locations: first as [4][7] (m. 4, bt. 2), then as UPI 11, a transparent sound complemented by the clarinet’s sustained A3 in constructing [5][6] (m. 4, bt. 3), and finally as a [5][6] trichord accompanying the word “mein” (mine) (m. 5, bt. 1). A concluding vocal [5][6] trichord overlaps with this final

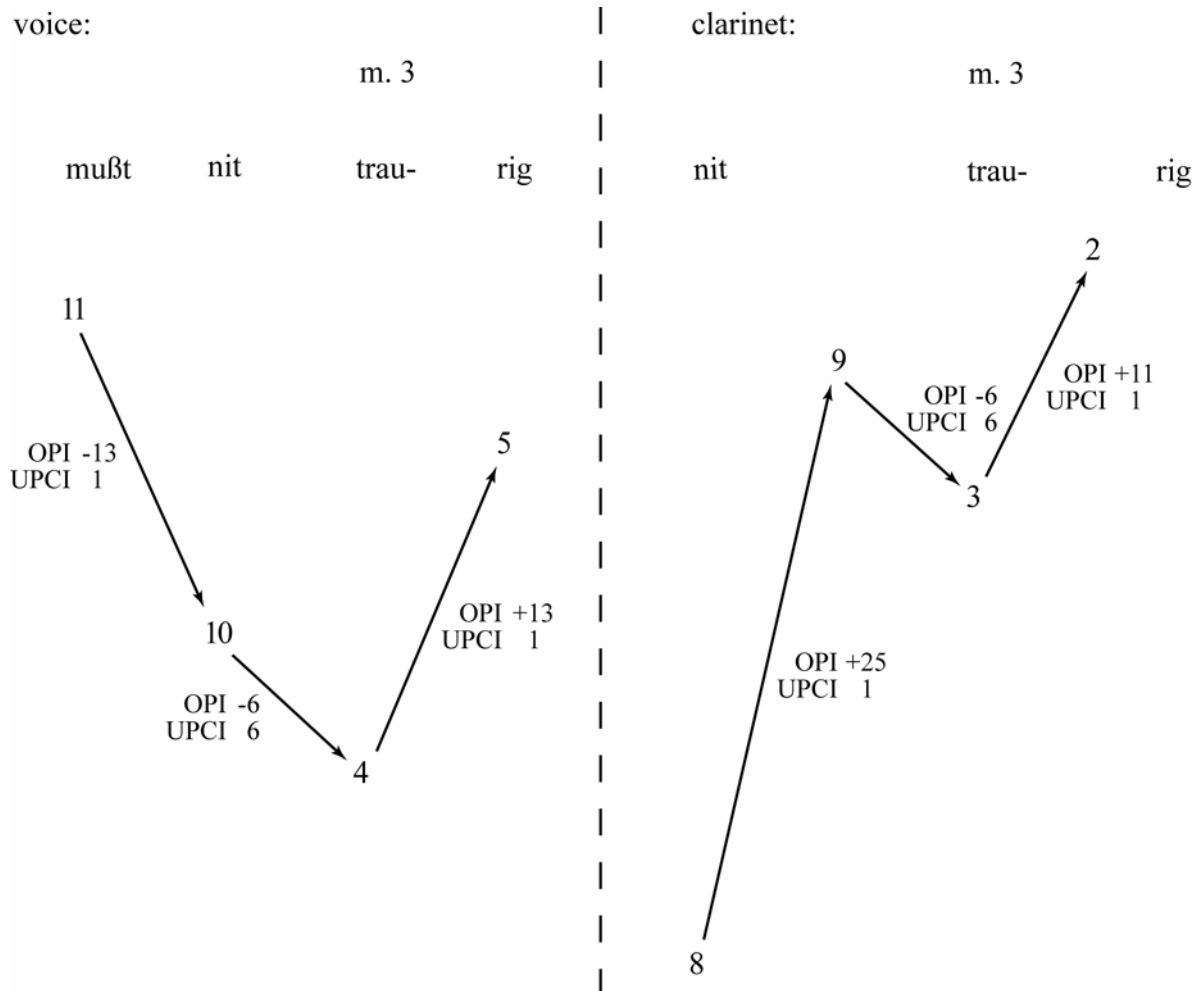

Fig. 3.5. Voice and Clarinet Intervals, mm. 2-3

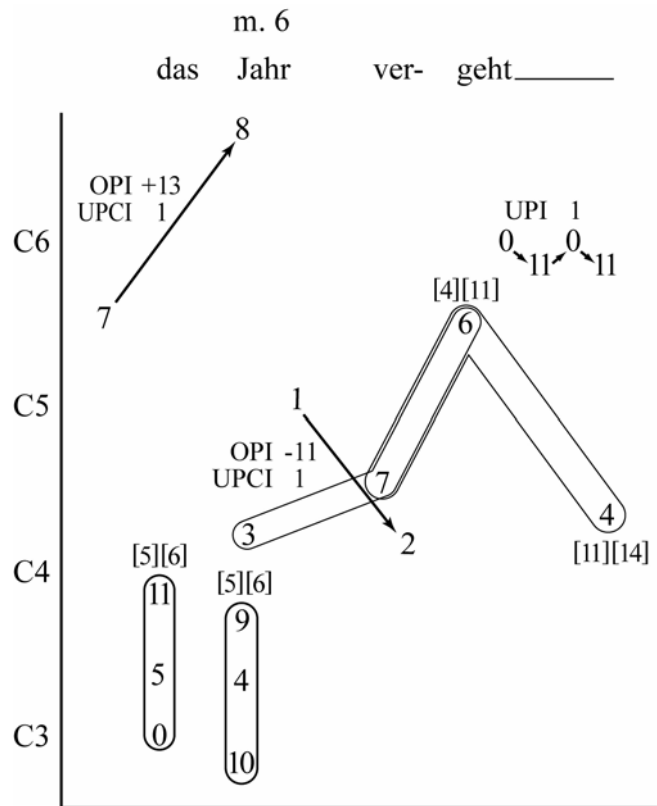

Fig. 3.8. Trichords and Intervals, m. 5, bt. 3-m. 6, bt. 2

recalls the IC makeup of [3][11], the trichord that largely defines the phrase “eh’ das Jahr vergeht” (before the year passes by) when the speaker first anticipates marriage with his beloved. Accompanying the vocal part, the clarinet presents ICs 1, 3, and 4 in a melodic line that sweeps past the blooming of the rosemary and concludes just before the speaker’s envisioned union with his beloved (mm. 6-8). Its B₆ at the syllable “Ros-“ sounds as the highest registral pitch of “Schatzerl klein” (m. 7, bt. 1). Immediately preceding the word “Rosmarin,” the guitar articulates a *mf* tetrachord built from two imbricated [5][6] trichords, the first instance in “Schatzerl klein” that the dynamic level exceeds *mp* (m. 6, bt. 3). At the word “Rosmarin,” guitar trichords [5][6] and [3][8] are evenly distributed among single guitar pitches. The resultant melody forms UPCIs 1, 3, and 4, a further reminder of the anticipatory phrase “eh’ das Jahr vergeht” (m. 7, bts. 1-2). The above-mentioned intervals thus draw on a gamut of overtones in creating an exciting blend of sounds that accompany the blooming of the rosemary (fig. 3.9).

clarinet, an expansive guitar phrase unfolds, its beginning and ending overlapping with the adjacent poetic lines. The guitar's copious expression of trichord [5][6], the sonority initially outlined in the first stanza, also reflects the climactic excitement of the envisioned wedding scene (mm. 8-9) (fig. 3.10).

The recurrence of the word "Rosmarin" (rosemary), the flower traditionally adorning virgin brides, is followed by the word "Myrtenstrauß" (myrtle bouquet), the bouquet whose scent connotes erotic love. Both are set in a musical texture saturated with few musical motifs (m. 9, bt. 3-m. 11). The guitar material beneath the phrase "grünt der Rosmarin, grünt der Myrtenstrauß" (the rosemary will be blooming, the myrtle bouquet will be blooming) consists almost entirely of first- and second-order [5][6] derivatives. Above the guitar, the voice renders a series of IC 1 statements formed either by consecutive or neighboring pitches. The arrival at the word "Myrtenstrauß" (myrtle bouquet) (m. 11, bt. 1) sets off a two-fold expression of IC 1, both the ornamental and main pitch sounding against the last note of the previous measure. This dual IC 1 statement draws particular attention to the word "Myrtenstrauß," the flower symbolizing the speaker's fantasy of sexual fulfillment with his beloved. Immediately preceding the word "Myrtenstrauß," the clarinet sounds ICs 1 and 3, both by the ornamental and main pitch pairs, at the words "grünt der" (will be blooming), a restatement of the anticipation motif (m. 10, bt. 3). In addition, an expansive clarinet OPI +23 forms between the last pitch of measure ten and the *fp* pitch that coincides with the word "Myrtenstrauß" in measure eleven. This broad interval, the second-largest to sound up to this point, further highlights the arrival at the association-laden word (fig. 3.11).

The blooming of the carnation stock is realized both by familiar and less-familiar musical material, the voice and clarinet restating oft-heard musical motifs and the guitar sounding new sonorities inserted among familiar harmonies (fig. 3.12). Trichord [5][6] recurs once again in the vocal line, this time preceding the word "Nagerlstock" (carnation stock), a symbol of the couple's transition into married life (m. 11, bt. 3). A melodic [5][6] is subsequently articulated by the clarinet just before the concluding line "blüht im Haus" (will be blooming in the house) affirms that the scent of the carnation stock has wafted throughout the couple's home (m. 12, bt. 2). Immediately preceding the [5][6] trichord, the voice and clarinet unfold a series of ICs 1, 3, and 4 at the phrase "und der Nagerlstock" (and the carnation stock), appropriately outlining the

recurring anticipatory intervallic motif. The clarinet's arrival upon the word "Nagerlstock" introduces the largest interval to sound in "Schatzerl klein." The final pitch of this ascending OPI +33 is sustained over the highest vocal pitch, a melismatic C#6 (m. 12, bt. 1). The OPI +21

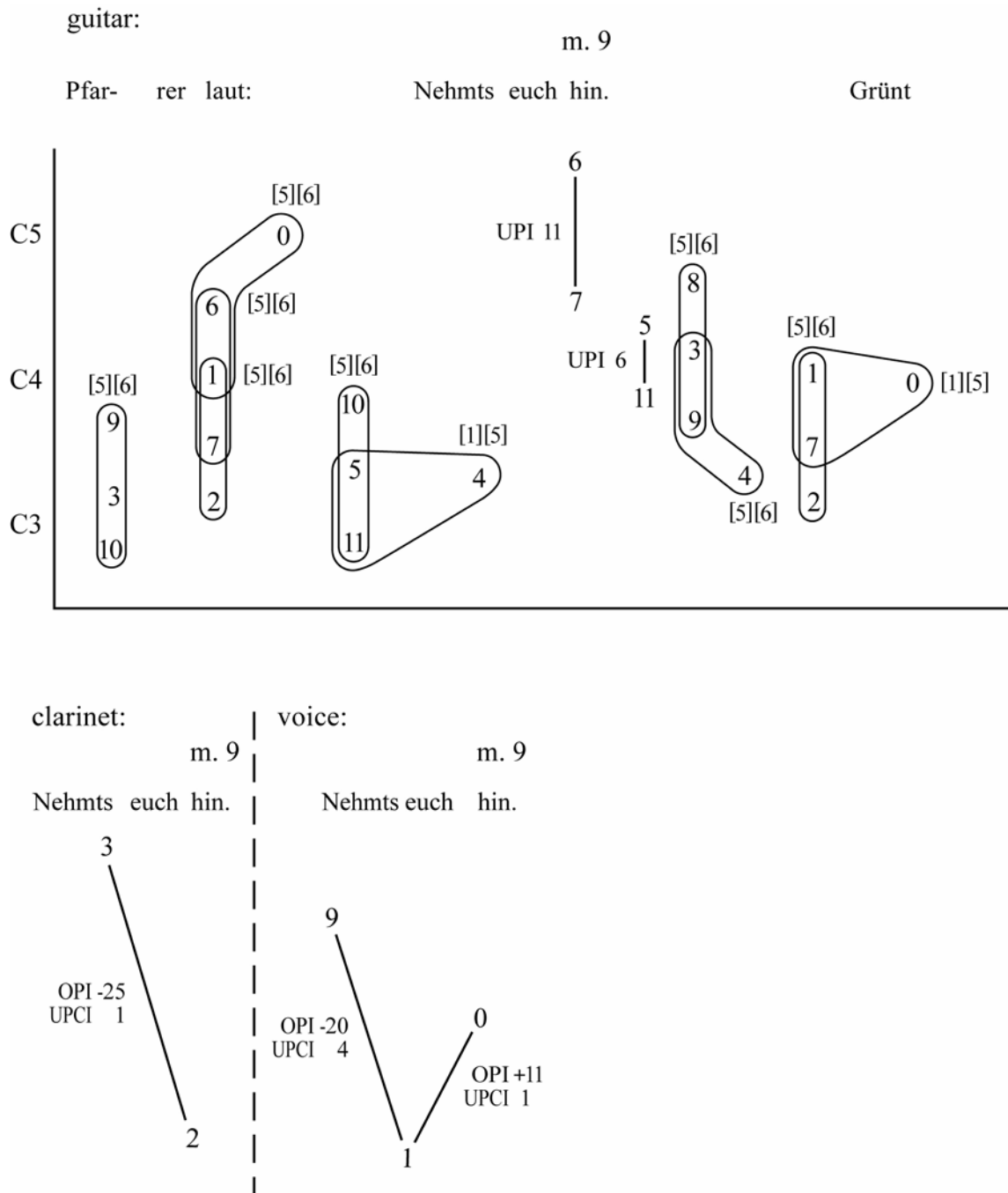

Fig. 3.10. Trichords and Intervals, mm. 8-9

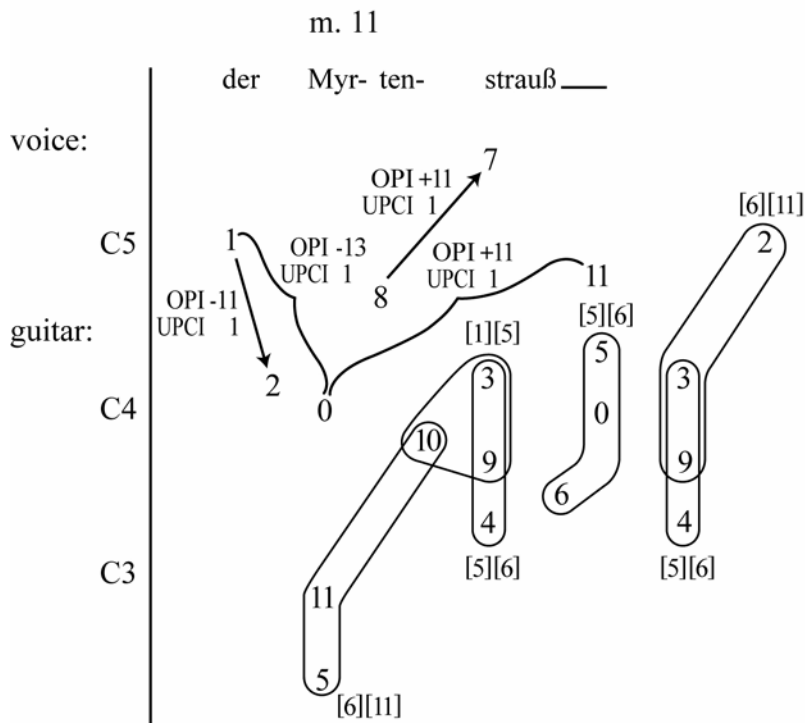
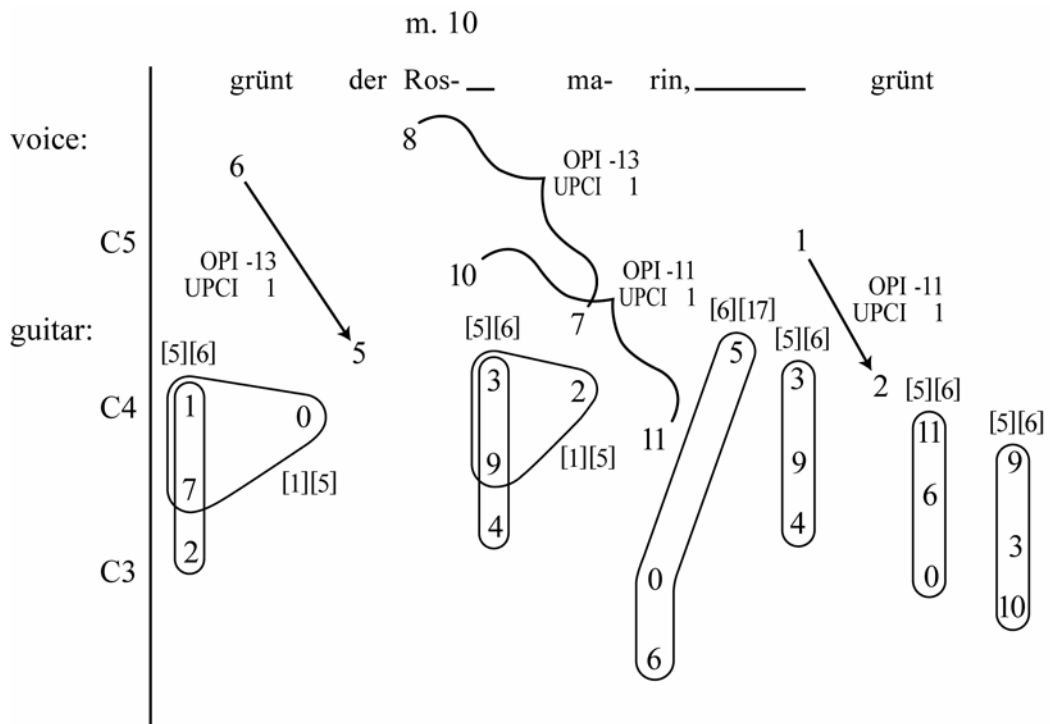

Fig. 3.11. Trichords and Intervals, m. 9, b. 3-m. 11

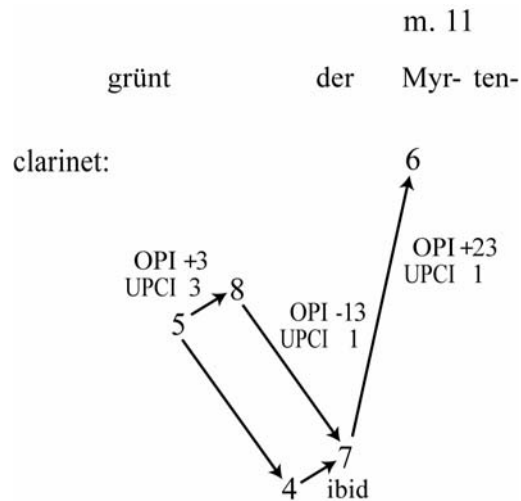

Fig. 3.11. Trichords and Intervals, m. 9, bt. 3-m. 11 (continued)

vocal interval formed between this pitch and the last pitch of the previous measure also represents the song’s largest intervallic vocal span. Both the voice and clarinet parts end with expanded IC 1s, OPIs -11 and -25 respectively, at the phrase “blüht im Haus” (will be blooming in the house), augmentations of the OPI -1 descent that concludes the opening guitar phrase (m. 12, bt. 3-m. 13, bt. 1). The large intervals thus sound as the speaker envisions long-term happiness with his beloved, a realization of the wistful ideas outlined in the first stanza. The clarinet’s initial B₆ represents the registral acme of “Schatzerl klein,” the pitch that sounded once before at the first utterance of the word “Rosmarin” (m. 12, bt. 3).

Although the guitar accompaniment consists primarily of trichord [5][6], it also introduces novel musical material, most notably at the concluding solo postlude. Up until the final two poetic lines, trichord [5][6], along with trichordal and intervallic derivations thereof, define the guitar material. New trichordal formations are introduced in the guitar part beginning at the word “Myrtenstrauß” (myrtle bouquet), a symbolic allusion to the couple’s embarkment on their married lives with one another. Beneath the “-strauß” syllable, trichord [3][5] sounds, an imbrication that recurs at the identical tetrachord positioned between the second and penultimate lines of the closing stanza (m. 11, bts. 2-3). In a similar manner, imbricated trichord [3][6] is

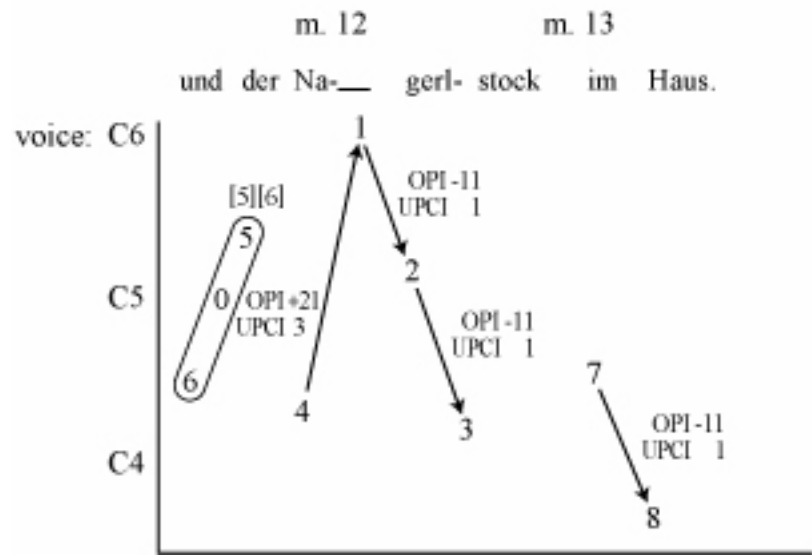
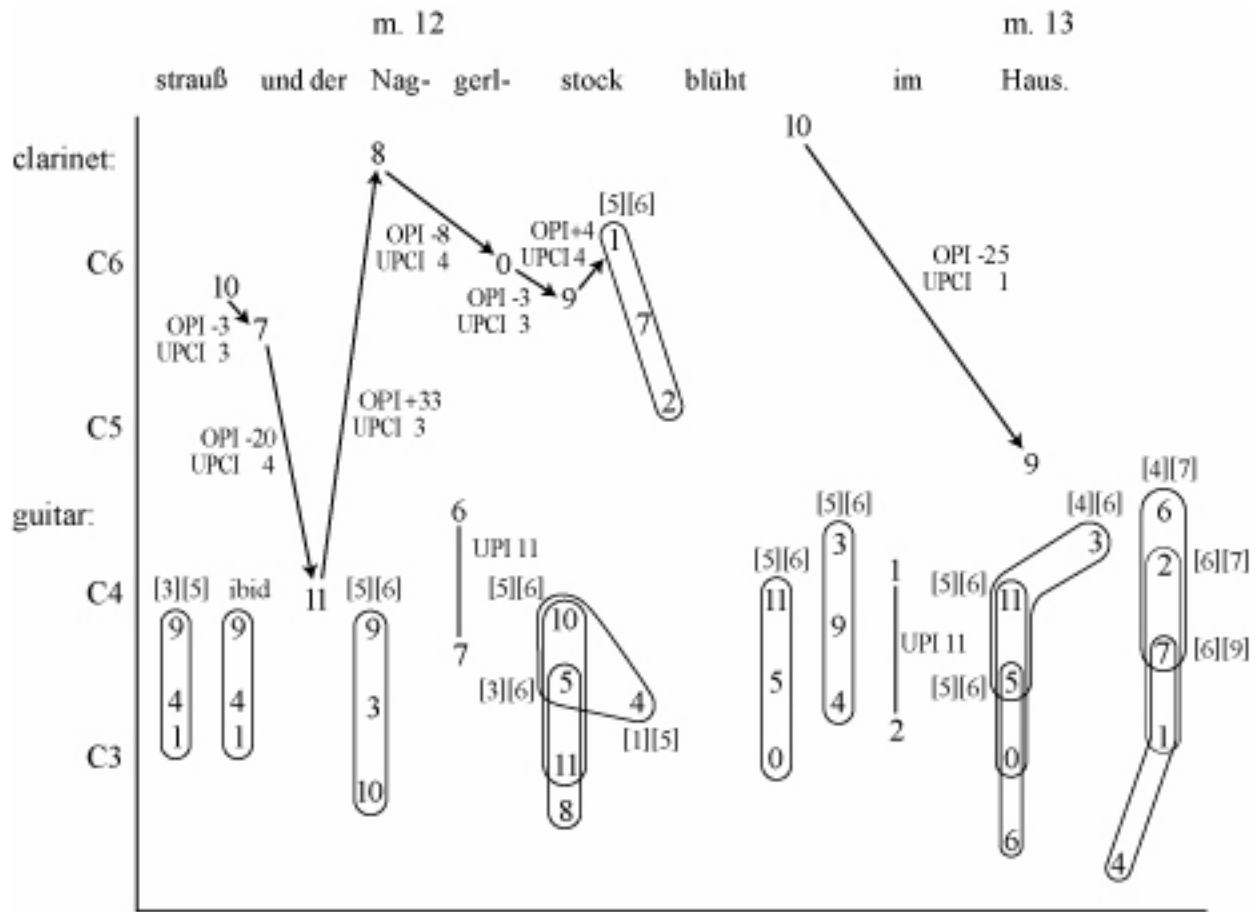

Fig. 3.12. Trichords and Intervals, m. 11, bt. 2-m. 13

formed at the harmonic tetrachord beneath the word “Nagerlstock” (carnation stock) (m. 12, bt. 2). Following the registral [4][6] trichord accompanying the word “Haus,” the guitar sounds imbricated trichords [6][9] and [6][7], followed by [4][7], a foreshadowing of the [4][7] influx that will take place throughout “Erlösung” (m. 13, bts. 1-2).

Similar to the trichordal analysis, a set analysis reveals that a limited number of sonorities underscore the simple message of the poetic text. Unlike Bernard’s trichordal method, however, set classification identifies the IC content of musical entities regardless of their pitch-interval values. The sets first outlined in the instrumental introduction recur repeatedly throughout “Schatzerl klein” as reinforcements to the poetic text (m. 1). First, two 3-5 guitar imbrications sound, a trichordal set built exclusively from ICs 1, 5, and 6. The brief introductory guitar phrase concludes with a 3-4 set formed on its final three melodic pitches. Trichord 3-4 is also articulated by the clarinet above the guitar phrase, a set whose (015) prime form is one semitone smaller than (016), the prime form of set 3-5 (fig. 3.13).

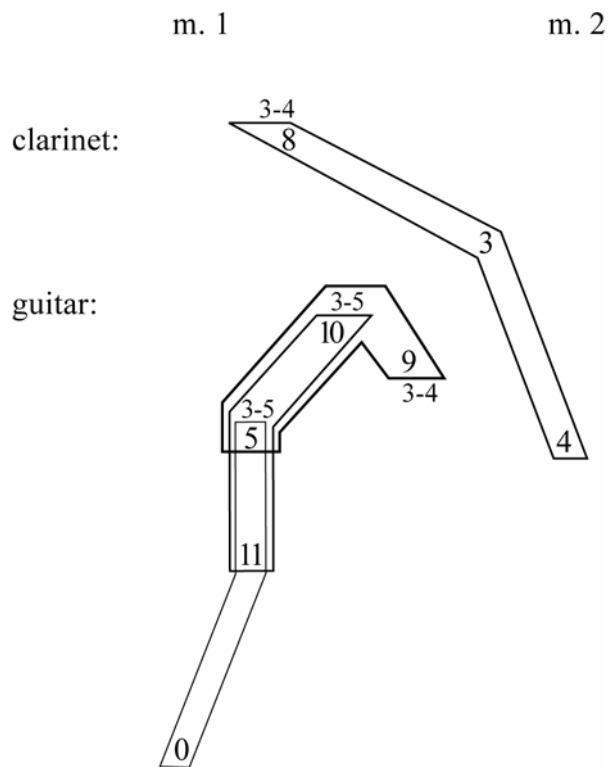

Fig. 3.13. Sets in the Instrumental Introduction

Throughout the first stanza, trichord 3-5 plays an important role in highlighting the structure of the poetic text. The rhyming of the second and fourth lines, “mußt nit traurig sein” (don’t be sad) and “bist du mein” (you will be mine) respectively, is accentuated by tetrachord 4-9, a set whose four subsets are all 3-5 members (mm. 2-3, mm. 4-5). Accompanying the words “traurig sein,” the guitar articulates set 4-9 along with the identical clarinet subset formed on the second melodic pitch at the word “nit” as further reinforcement to the vocal set (m. 2, bt. 3-m. 3, bt. 1). A harmonic 3-5 guitar set sounds beneath the word “mein,” a trichord that merges with the subsequent guitar material in creating its 9-5 complement (m. 5, bts. 1-2).

Set 3-4 accentuates the poetic structure of the first stanza in two ways: it demarcates the stanza’s beginning and ending and underscores the contrasting rhyme of the third line. The overlap of sets 3-4 and 3-5 in the instrumental introduction is complemented by a similar set juxtaposition that concludes the third stanza. The final clarinet melody extends over the closing vocal line, its 3-4 set overlapping with the 3-5 formed at the words “bist du” (you will be) (m. 4, bts. 2-3). In addition, the harmonic guitar 3-4 sets that frame the phrase “eh’ das Jahr vergeht” (before the year passes by) are interpolated with a harmonic 3-5 set (m. 3, bt. 3-m. 4, bt. 2).

The contrasting third line is further reinforced by the melodic lines of the voice and the clarinet. Sounding above the harmonies of the guitar, set 3-3 unfolds in two consecutively descending clarinet lines (m. 3, bt. 2-m. 4, bt. 1). Webern manipulated non-adjacent row members to formulate the 3-3 sets, a sonority that does not appear at all in the Op. 18, no. 1 row. The first four pitches of the vocal phrase “Jahr vergeht” (year passes by) create tetrachord 4-Z15, the Z-correspondent to 4-Z29, a set that occurs twice in the row (m. 4, bts. 1-2). Its all-interval content hints at the fulfillment of the couple’s relationship envisioned by the speaker.

Following the first stanza, trichord 3-5 recurs infrequently throughout the vocal and clarinet melodies as an indicator of the impending changes that will take place in re-defining the couple’s relationship. The set is articulated as a pair of imbricated trichords at the phrase “sagt der Pfarrer laut” (and the priest will say loudly), immediately before the speaker and his beloved are joined together in marriage (mm. 7-8). A final vocal 3-5 set forms at the words “und der” (and the) as an aural harbinger of the impending long-term happiness awaiting the couple (m. 11, bt. 3). The clarinet sounds set 3-5 immediately preceding the phrase “blüht im Haus” (will be blooming in the house), an affirmation that the scent of the carnation stock will spread

throughout the home of the newlyweds (m. 12, bt. 2).

Unlike the voice and clarinet parts, trichord 3-5 is stated pervasively throughout the guitar part in the second and third stanzas of “Schatzerl klein” (fig. 3.14). Four of the six harmonic chords accompanying the anticipatory phrase “eh’ das Jahr vergeht, grünt der Rosmarin” (before the year passes by, you will be mine) are 3-5 members (m. 5, bt. 3-m. 7, bt. 2). With the exception of the stacked perfect fourths chord (m. 6, bt. 2), a 3-3 trichord appearing beneath the final “-rin” syllable is the only dissimilar harmonic set to sound (m. 7, bt. 2). This trichord anticipates the dramatic vocal enunciation of set 3-3 during the speaker’s envisioned nuptials. The guitar renders an exclusive series of 3-5 trichords at the priest’s pronunciation “Nehmts euch hin” (take one another) (mm. 8-9). The subsequent phrase “grünt der Rosmarin, grünt der Myrtenstrauß” (the rosemary will be blooming, the myrtle bouquet will be blooming) also features a concentrated succession of 3-5 sets (mm. 10-11).

The 3-5 succession that continues throughout the final poetic couplet is interjected with less-familiar sets, 3-11 and 3-10 respectively, sounding beneath the final syllable of the words “Myrtenstrauß” (myrtle bouquet) and “Nagerlstock” (carnation stock) (m. 11, bt. 2; m. 12, bt. 2). In addition, the 3-8 registral subset accompanying the word “Haus” is followed by a concluding 3-10, the lowest registral set of the closing guitar figure (m. 13). The final two 3-10 trichords are conjoined with imbricated 3-5s to form 4-13 sets, both tetrachords built from adjacent row members. As with the trichordal analysis, the insertion of foreign sets at the end of the song suggests future changes that will develop throughout the couple’s marriage.

Similar to the first stanza, set 3-5 sounds in conjunction with 3-4: at the beginning, middle, and ending poetic lines. The opening vocal line “Schatzerl klein, muß nit traurig sein” (Little sweetheart, don’t be sad) concludes with a 3-4 set followed by two 3-5 sets (mm. 2-3). Both sets shape the culminating phrase “grünt der Rosmarin” (the rosemary will be blooming), the poetic line that precedes the scene of the speaker’s envisioned nuptials. The expectant phrase commences with two 3-4 sets followed by a single 3-5 set (mm. 6-7). In a similar fashion, sets 3-5 and 3-4 mark the beginning of the final poetic couplet at the phrase “und der Nagerlstock” (and the carnation stock), a signal the couple will establish a life of marital happiness. The opening guitar figure is echoed in the harmonic tetrachord that concludes “Schatzerl klein.” Set 3-5 sounds as an imbricated trichord beneath set 3-4 (m. 13, bt. 2).

m. 8

Pfar- rer laut:

m. 9

Nehmts euch hin.

grünt

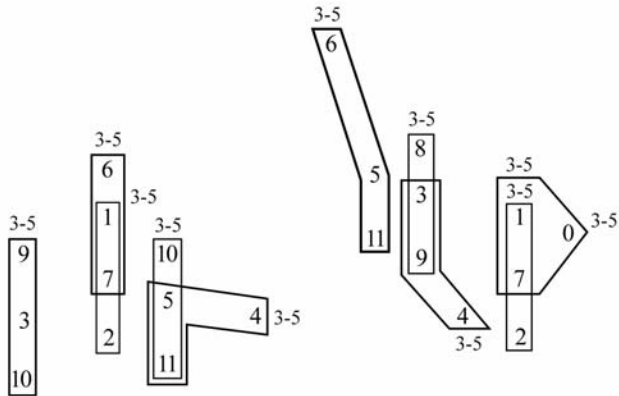

m. 10

Ros- ma- rin,

m. 11

grünt

der Myr- ten- strauß

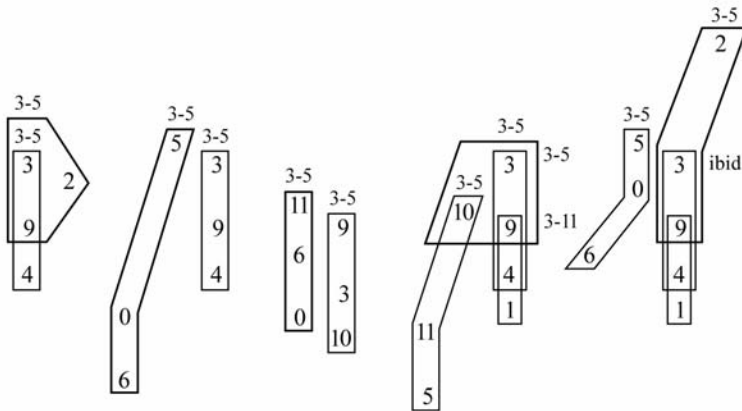

Na- gerl- stock

blüht

im Haus.

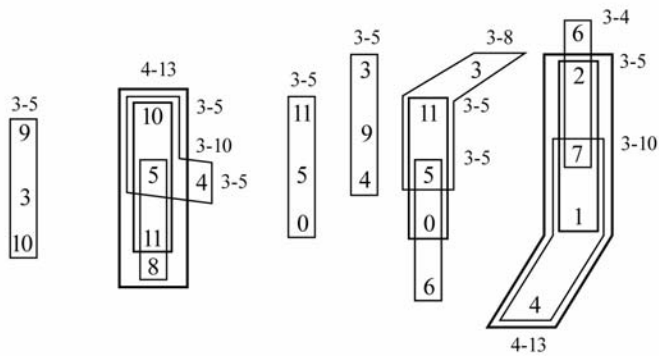

Fig. 3.14. Guitar Sets in Stanzas Two and Three

Hexachord 6-5 resurfaces at significant junctures throughout “Schatzerl klein” as an aural indicator that the couple’s relationship envisioned by the speaker has arrived at a new stage. The set is rife with the sound of subset 3-5, the trichord outlined throughout the first stanza.

Hexachord 6-5 is articulated at the phrase “bist du mein” (you will be mine) as a subset formed by the voice and clarinet (mm. 4-5). The speaker’s joyful anticipation that he and his beloved will be united in matrimony is thus accompanied by a culminating statement of 3-5 trichords. Hexachord 6-5 is prominently displayed at the vocal phrase “grünt der Myrtenstrauß” (the myrtle bouquet will be blooming), appropriately during the consummation scene (mm. 10-11). In a similar manner, hexachord 6-5 sounds as a harmonic guitar set beneath the phrase “im Haus” (in the house) (m. 12). The set thus emerges as the scent of the carnation stock filters throughout the newlyweds’ home.

Z-related sets 4-Z29 and 4-Z15 recur throughout “Schatzerl klein” as an indicator of impending developments in the couple’s relationship (fig. 3.15). A cluster of seven vertical 4-Z15 and 4-Z29 sets materialize at the blooming of the rosemary, just before the word “Myrtenstrauß” (myrtle bouquet) is uttered (m. 10). The word “Rosmarin” is accompanied by guitar tetrachord 4-Z15 (m. 10, bts. 1-2). Its Z-correspondent appears beneath the “-strauß” syllable, a harmonic tetrachord that is repeated following the conclusion of the penultimate stanza (m. 11, bts. 2-3). Harmonic 4-Z15 imbrications sound simultaneously at both junctures, both sets built from the blending of the guitar sonorities with the voice and clarinet melodies respectively. The final guitar and clarinet pitches form an additional 4-Z15 tetrachord beneath the “-strauß” syllable (m. 11, bt. 2). Tetrachord 4-Z29 is articulated by the clarinet immediately preceding the word “Nagerlstock” (carnation stock), the flower symbolizing the beginning of the couple’s married life. In addition, the clarinet and vocal melodies merge in sounding 4-Z15 (m. 11, bt. 3). An affirmation that the scent of the carnation stock has permeated the home of the newlyweds is indicated by the word “Haus” (house), a word shaped by the lower registral vertical subset 5-19 of which the lower tetrachord is 4-Z29. The sustained pitches of the guitar overlap with the clarinet’s A4 in building an additional statement of 5-19. Tetrachord 4-Z29 sounds this time as the higher registral subset (m. 13, bt. 1).

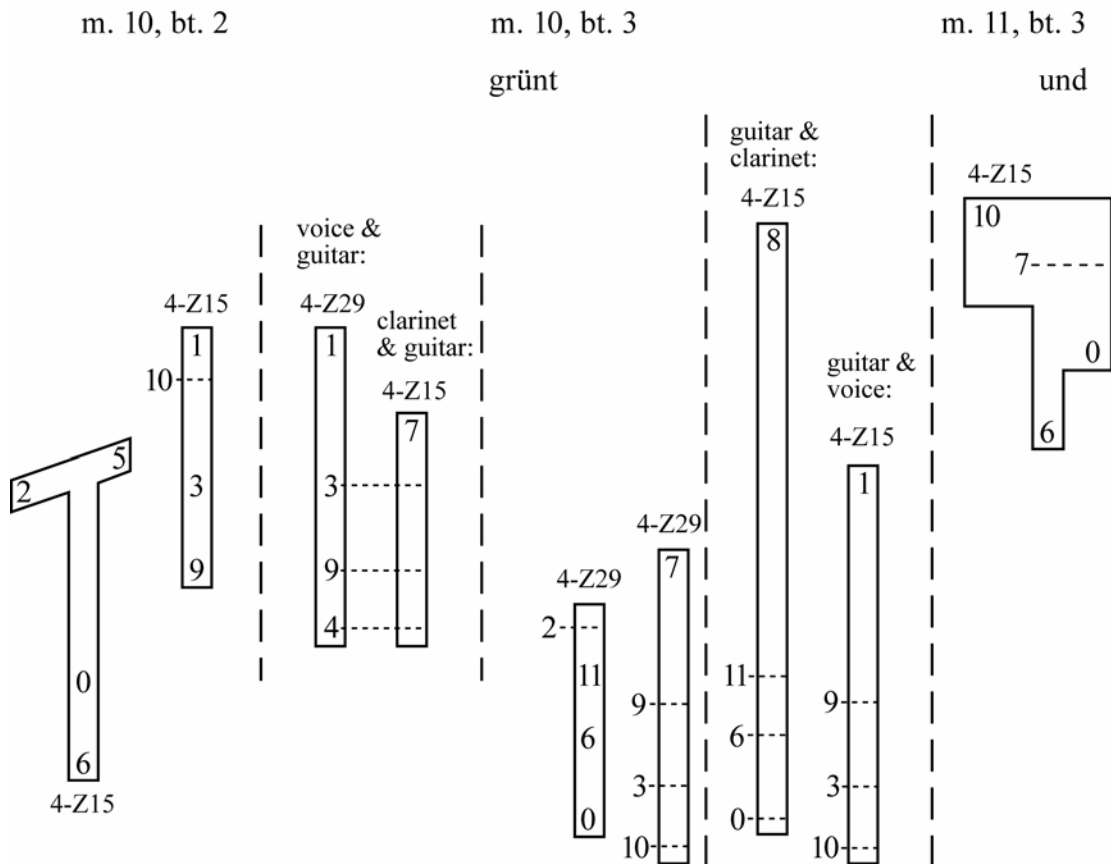

Fig. 3.15. Tetrachords 4-Z15 and 4-Z29

Hexachord 6-Z3 plays an important role in defining the transitional moments throughout the second and third stanzas of “Schatzerl klein” as a sonority built from non-adjacent row members. The repeated phrase “Eh’ das Jahr vergeht” (before the year passes by) is cast as 6-Z3, a set whose 433221 IC vector reveals that the tension-laden ICs 1 and 6 constitute a third of its members (mm. 5-6). The subsequent line, “grünt der Rosmarin” (the rosemary will be blooming) also sounds 6-Z3, the anticipatory quality of its dense chromaticism characterizing the pre-wedding scene (mm. 6-7). The vocal “-rin” syllable of the word “Rosmarin” blends with the guitar accompaniment in forming 6-Z36, the Z-correspondent to 6-Z3 (m. 7, bt. 2). Hexachord 6-Z3 recurs at the repeated phrase “grünt der Rosmarin” (the rosemary will be blooming) as a large subset encompassing all but the final melismatic vocal pitch (mm. 9-10). The anticipatory 6-Z36 is built by the clarinet and guitar beneath the words “grünt der” (will be blooming)

preceding the consummation scene (m. 9, bt. 3). Hexachord 6-Z3 sounds once more at the words “Nagerlstock blüht im” (carnation stock blooms in the), significantly omitting the final word “Haus” (house), the word that affirms that the carnation stock scent has spread through the couple’s new home (m. 12). The clarinet and guitar articulate set 6-Z36 at the beginning of the word “Nagerlstock” (carnation stock) as a further reinforcement to the anticipatory motif (m. 12, bt. 1).

Additional related sets establish aural unity throughout the final poetic couplet of “Schatzerl klein.” Vertical pentachord 5-Z36 accompanies the word “Haus” (house) as the higher pentachord imbrication (m. 13, bt. 1). The final solo guitar phrase forms set 5-Z12, the Z-correspondent to the harmonic pentachord. The sonority that sounds as an affirmation of the couple’s long-term happiness is thus recalled by the guitar postlude figure. Guitar nonachord 9-1 appears beneath the word “Nagerlstock” (m. 12, bt. 1), followed by two complementary 3-1 sets, the concluding voice and clarinet melodies (m. 12, bt. 3-m. 13, bt. 1). Finally, consecutive statements of 8-2 sound in the guitar accompaniment as a distinct subset spanning all but the final pitch at the word “Nagerlstock” and an octachord appearing beneath the words “blüht im” (m. 12).

The contours of the first stanza also reinforce the as-yet-unfulfilled nature of the relationship between the speaker and his beloved, as well as the speaker’s joyful anticipation of its consummation, a vision not elaborated on until the second and third stanzas. The fragmentary, pointillistic guitar writing of the first stanza, in which none of the contour segments consist of more than two contour pitches, is framed by two slightly longer guitar contour segments sounding both in the instrumental introduction (m. 1) and the brief interlude following the first stanza of “Schatzerl klein” (m. 5). Contour segment <021> of the guitar interlude clearly refers back to the guitar contour subsegment <021> in the instrumental introduction. This <021> subsegment is highlighted by the registral proximity of its pitches, which are spatially removed from the beginning pitch C3 (fig. 3.16).

Contour <021> is sporadically realized by the clarinet and the voice throughout the first stanza of “Schatzerl klein,” along with the motif of a descending melodic line. The laconic descending figure <210> played by the clarinet throughout the first stanza is momentarily interjected by contour <102> over which the voice sings the overlapping contour <120> (m. 2),

the RI and R forms of <021> respectively, immediately followed by the clarinet's echoing of <120> in measure three (Fig. 3. 17).

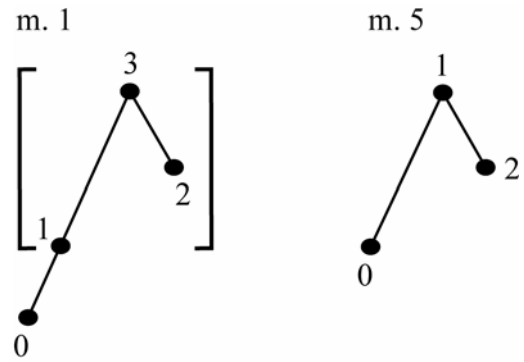

Fig. 3.16. Guitar Contours, Stanza One

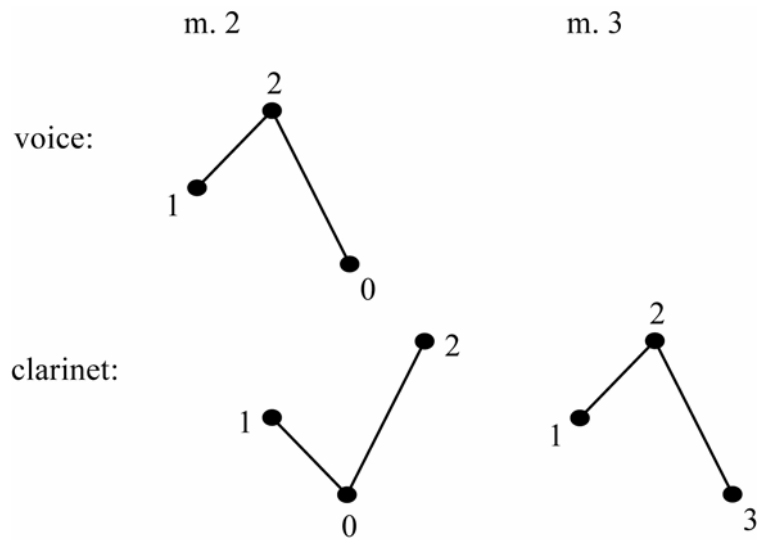

Fig. 3.17. Voice and Clarinet Contours, mm. 2-3

Then the voice sings the melismatic contour <021> on the second stressed syllable of the word “vergeht” (passes by), a contour that will feature prominently in the dense musical texture of the second and third stanzas when the speaker vividly unfolds his dream that will be realized before the passing of the year (m. 4, bt. 2). The final vocal contour, a softly cascading <3210>, is mirrored by the descending clarinet figure in marking the conclusion of the stanza as the speaker reassures his beloved that they will soon be together (mm. 4-5). Throughout the first stanza, the intermittent occurrences of contour <021>, along with the descending melodic figure, hint at a fuller realization of this musical material in the second and third stanzas. The traversing contour pitches of <021> embody the changing course of the relationship that will develop between the speaker and his beloved: the lowest beginning pitch as their courtship stage, the sweeping ascent to the apex of the contour as the flurry of excitement leading to their wedding, and the descent to the midway point of the contour as the settling of their lives into one of serene marital happiness.

In the second stanza, contour <021> and the descending motif play a prominent role in distinguishing the sound of the anticipated wedding scene. The reiteration of the vocal phrase “Eh’ das Jahr vergeht” (before the year passes by) is rife with the sound of contour <021> (mm. 5-6). Two abutting statements of the contour, first as a rapid statement of three sixteenth notes, then as a contrasting rhythmic subsegment formed on the accented syllables of the phrase “Jahr vergeht” (year passes by), combine in creating a third statement of <021> arrived at by means of Robert Morris’s contour reduction algorithm (fig. 3.18).

Vocal contour <021> is further reinforced by the identical subsegment played by the guitar on the first beat of measure six. The next occurrence of <021> emerges dramatically as the prime form of the large clarinet contour sounding at the blossoming of the rosemary just before the speaker and his beloved are joined together in marriage (mm. 6-8). Motion from the first to the second contour pitch is accentuated by the clarinet’s expansive intervallic span of [33], its largest one, which begins on C#4 and culminates in the arrival on Bb6 at the word “Rosmarin” (rosemary), the registral acme of “Schatzerl klein” (m. 6, bt. 3-m. 7, bt. 1). The second contour pitch thus coincides with reference to the flower that symbolizes the marital rite of passage (fig. 3.19).

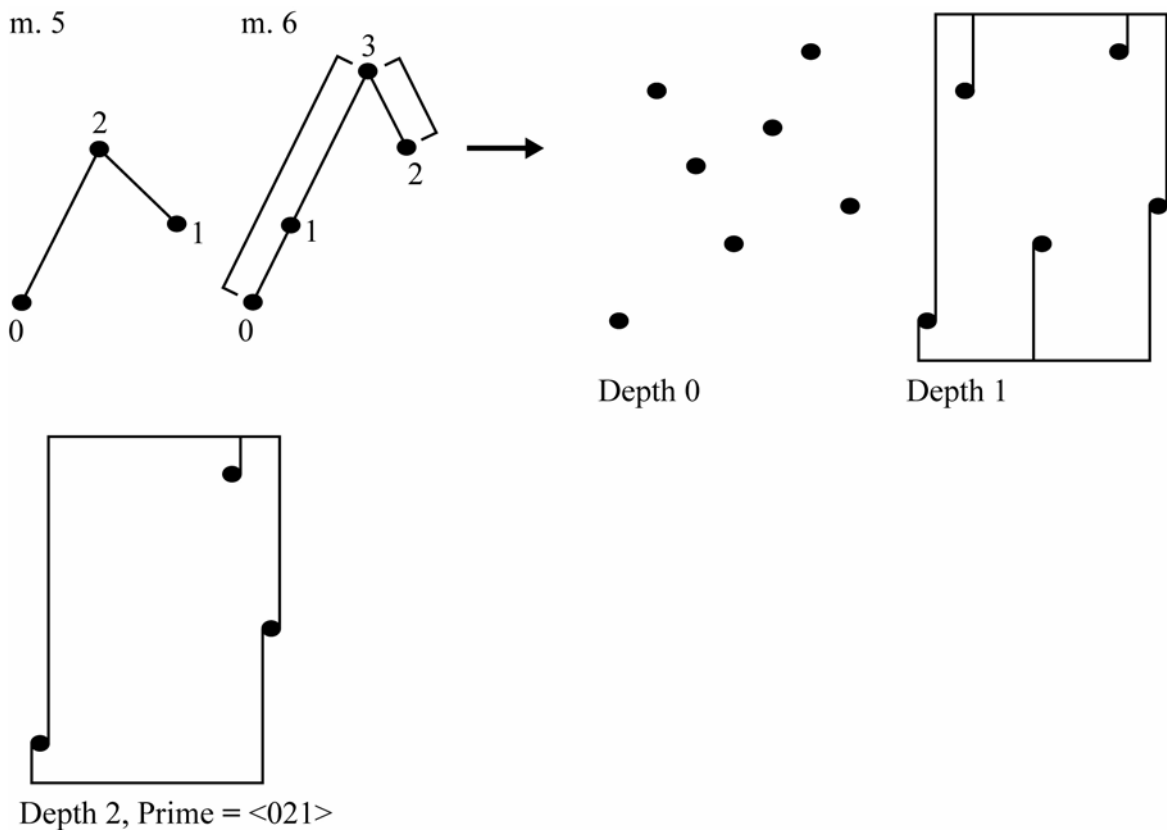

Fig. 3.18. Vocal Contour <021>, mm. 5-6

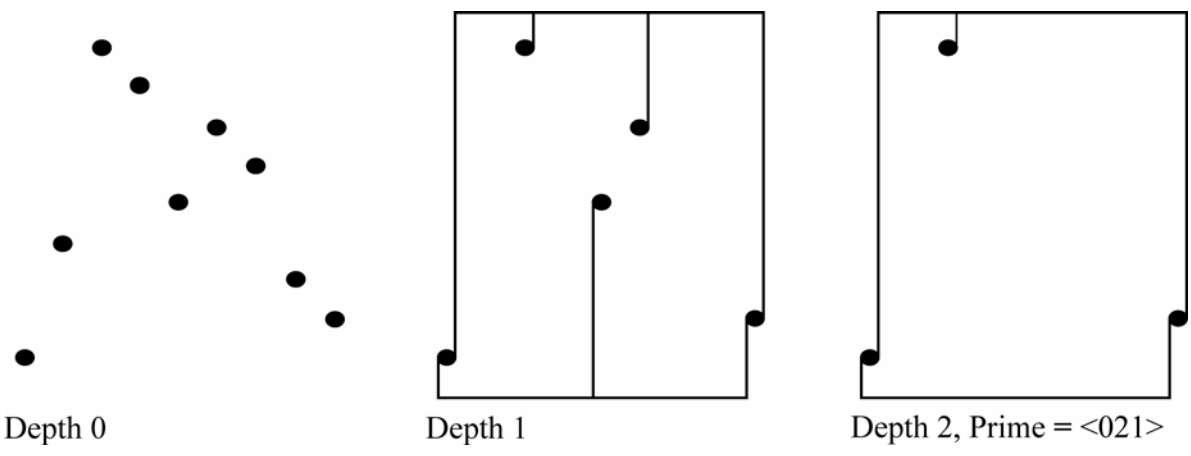

Fig. 3.19. Clarinet <021>, mm. 6-8

Contour <021> then re-emerges in its inverted form as <201>, a figure whose final ascent

lends itself to the anticipation of musical material to come. The vocal triplet figure sung at the consequential word “Rosmarin” (m. 7, bt. 1) is prefigured slightly by the guitar contour formed on the *mf* pickup chord and the two ensuing sonorities sounding in the first beat of measure seven, significantly, one of three brief instances when the guitar’s dynamic level rises above *mp*. The final two-note ascent of contour <021> is echoed both by the guitar (m. 7, bts. 1 and 2; m. 8, bts. 1-2), then by the voice (m. 7, bt. 3; m. 8, bt. 1) before culminating in a complete vocal statement of <201> during the priest’s sanctification of the conjugal union (mm. 8-9).

The descending motif returns again, this time as a striking two-note clarinet figure accompanying the priest’s pronouncement of the couple’s union. A *fp* execution of this figure as well as its contrasting articulation, a *tenuto* E_b6 followed by a succession of three *staccato* D4’s, transform it into an embodiment of the sweeping change that has just taken place (mm. 8-9). The descending figure is played once more by the clarinet in its more familiar role as an indicator of the stanza’s conclusion, this time overlapping with the beginning of the third stanza (m. 9). Simultaneous with the D4’s of the clarinet, the guitar renders its own version of the two-note descending motif as a series of subcontours within the second measure of an extended, two-measure guitar phrase (mm. 8-9). A descending *staccato* triplet figure, two repeated melodic F#5s followed by an F#4, is sounded by the guitar, a gesture that begins at a *f* dynamic level, the only such occurrence in the guitar part (m. 9, bt. 1). Then, a contrasting two-note *tenuto* figure cast in duple meter is played by the guitar, followed by a slurred, two-note figure in triple meter that, similar to the clarinet’s descending motif, acts as a liaison between the second and third stanzas (m. 9, bts. 2-3).

The <201> contour featured so prominently in the second stanza returns again in the vocal line of the third stanza at the recurrence of the word “Rosmarin” (rosemary), a subcontour formed on its accented syllables (m. 10) (fig 3.20). The expectant sound of this vocal contour at the reference to the flower symbolizing virginity is followed by the return of contour <021> on the word “Myrtenstrauß” (myrtle bouquet), the flower whose erotic scent symbolizes the consummation of the couple’s love (m. 11). The denouement of its final descending arc serves as an aural indication of the speaker’s envisioned fruition of the relationship. Significantly, the guitar sounds the familiar <021> contour beneath the <201> vocal contour at the word

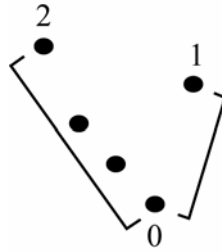

Fig. 3.20. Vocal Contour <201>, m. 10

“Rosmarin,” its presence serving as a reminder of the relationship’s impending evolution from its courtship stage to its status of marital fulfillment (m. 10, bt. 2). The guitar follows with the retrograde of <201>, the <102> prime form of a large, nine-pitch contour beneath the words “grünt der Myrtenstrauß” (the myrtle bouquet will be blooming) (m. 10, bt. 3-m. 11). The extended upward spiral of this contour sounds as a full realization of the final ascent of the sparse <201> contour sung during the envisioned wedding scene (fig. 3.21).

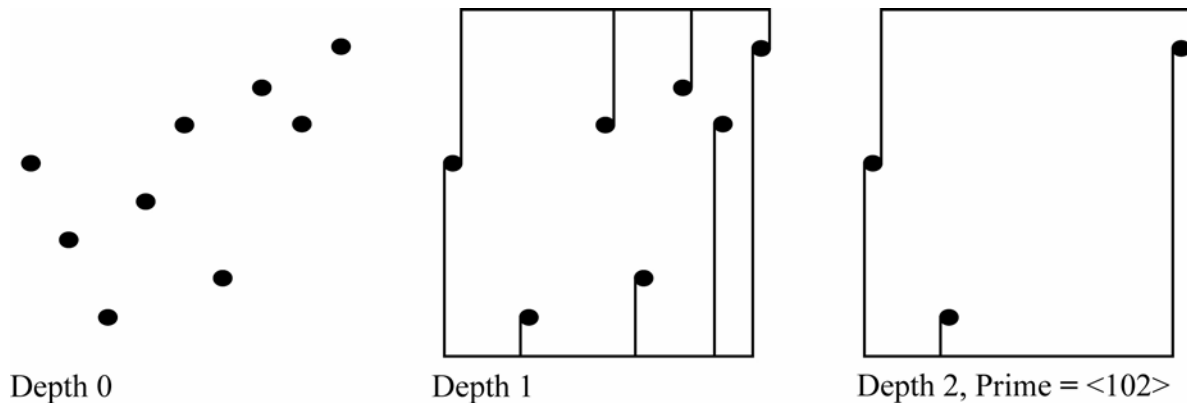

Fig. 3.21. Guitar Contour <102>, m. 10, bt. 3-m. 11

The identical contour is also played by the clarinet, its last contour pitch highlighted by means of the *fp* dynamic execution, one of two times the clarinet plays louder than *mp* (mm. 10-11).

Contour <1320> is sung by the voice at the word “Nagerlstock” (carnation stock), the outermost pitches articulating <120>, the retrograde of <021> (fig. 3.22).

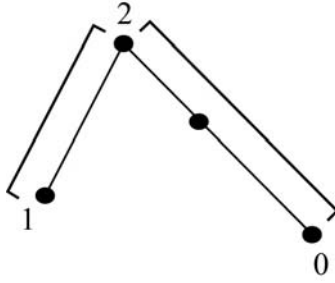

Fig. 3.22. Voice Subcontour <120>, m. 12

The guitar echoes contour <1320> beneath the word “Nagerlstock,” the beginning contour pitch accentuated by a *mf* dynamic marking, the third momentary instance in which the guitar’s dynamic level rises above *mp*. The clarinet reinforces the downward descent of <1320> in a phrase beginning at F#6 (m. 12), a note whose arrival is accentuated by its OPI +33 ascent from B3 in the previous measure, a reiteration of the clarinet’s largest interval sounding this time by two adjacent pitches (mm. 11-12). The waft of the carnation stock, whose scent was traditionally believed to act as a deterrent against disease and demonic forces, augurs the domestic life of felicity the speaker foresees for himself and his beloved. Its bloom is appropriately marked by subcontour <021>, the aural incarnation of the couple’s relationship, which clearly sounds as a triplet figure on the first two syllables of the word “Nagerlstock” (m. 12, bt. 1). This is followed by the final descending <210> vocal contour on the phrase “blüht im Haus” (will be blooming in the house) that ushers in the couple’s settling into their married lives (mm. 12-13). Beneath this figure, the clarinet and the guitar deliver tranquil closing statements of contour <021> followed by the guitar’s *pp* presentation of a two-pitch ascending contour, which is reiterated as a *ppp* accented note and a rolled chord (m. 13). The ascending figure that was dramatically articulated during the narrator’s envisioned wedding scene is thus transformed at the end of “Schatzerl klein” into a subdued expression of long-term marital happiness.

CHAPTER FOUR

OP. 18, NO. 2 (“ERLÖSUNG”): THE REDEMPTION OF CHRIST

Webern’s clear-cut setting of the cheerful “Schatzerl klein,” a poem whose simple utterances of joy are expressed in the regularity of its line schema, is followed by the contrasting irregularities of “Erlösung” (Salvation) (Fig. 4.1). An intense religious dialogue is contained in the asymmetrical lines of the poetic text, many of which closely resemble prose. In the first stanza of “Erlösung,” Mary entreats Christ to look upon her as an ideal figure of purity whose presence allows sinners to gain salvation. Christ responds in the second stanza by asking his mother to gaze upon his wounds that were inflicted on him by her sins. The poetic text portrays here a view of Mary as an inheritor of Eve’s sin which dates prior to the mid-nineteenth century.⁷⁵ Christ turns to God in the second part of the stanza and implores him to consider his wounds as a sacrifice for the sins of man. In the third and final stanza, God tenderly addresses Christ as his “dear son” before granting him his wish.

⁷⁵Beginning in the thirteenth century, a long-lasting doctrinal dispute was waged between the Dominican “maculates” and the Franciscan “immaculates” as to whether or not Mary had been born with original sin. On 8 December 1854, Pope Pius IX declared in the *Constitution Ineffabilis Deus* that she was indeed exempt from the stain of original sin. Webern’s selection of the “Erlösung” poem, which articulates a rejected Catholic dogma, at first appears to be inconsistent with his identification as a modern-day Roman Catholic. In addition to being born and raised in the Catholic faith, he continued to practice Catholicism throughout his adulthood. The composer kept meticulous records of his children’s confirmation dates and attendant family celebrations. At the same time, he rejected the fundamental Catholic idea of an intermediary standing between himself and God, abstaining from the rites of confession and Holy Communion. Webern did not attend Mass with his family on holy days, but frequently sought out an empty church or chapel in which to pray (Moldenhauer and Moldenhauer, *Anton von Webern: A Chronicle of His Life and Work*, 355). His ability to reconcile such seemingly opposing religious views is in line with his choosing the theologically outdated “Erlösung” to represent Mary as an incarnation of motherhood.

“Erlösung”		“Salvation”
Marie:		Mary:
Mein Kind, sieh an die Brüste mein,	A	My child, look upon my breast,
kein Sünder laß verloren sein.	A	Let no sinner be lost.
Christus:		Christ:
Mutter, sieh an die Wunden,	B	Mother, look upon the wounds
die ich für dein Sünd trag alle Stunden.	B	That I carry every hour for thy sins.
Vater, laß dir die Wunden mein,	A	Father, let Thou my wounds
ein Opfer für die Sünde sein.	A	Be a sacrifice for sin.
Vater:		Father:
Sohn, lieber Sohn mein,	A	Son, my beloved son,
alles, was du begehrt, das soll sein.	A	All that you wish for, it shall come to pass.

Fig. 4.1. “Erlösung,” Rhyme Schema and English Translation⁷⁶

Unlike “Schatzerl klein,” several phrases of the speech-like “Erlösung” are resistant to poetic scansion.⁷⁷ Webern’s durational setting of the vocal lines reflects both the metric regularity and the ambiguity contained within the poetic text. In the first part of the poem, Mary’s soothing reassurance that her presence provides redemption for sinners is expressed in a line schema executed with perfect iambic regularity. Both lines of her dialogue consist of four poetic feet, the accented syllable that concludes the first line blending seamlessly into the unaccented syllable of the second line. The durational lengths of the pitches correspond to the consistent regularity of the iambic metrical pattern (fig. 4.2).

⁷⁶Translation by the author.

⁷⁷I have not placed metrical markings on these phrases.

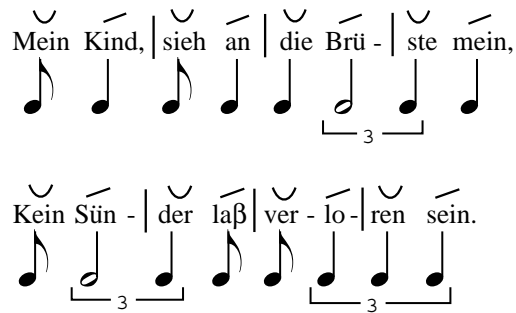

Fig. 4.2. Durational Lengths of the Vocal Pitches, Stanza One

Christ's anguished speech in the second stanza begins with a contrasting trochaic foot at the two-syllable word "Mutter" (mother). The juxtaposition of its initial accented syllable with the final accented syllable of the first stanza places a striking emphasis on Christ's invocation to his mother. The first syllable of the subsequent phrase "sieh an die" (look upon the) commences with a weak beat following the weak beat on the second syllable of the word "Mutter" that also draws attention to the words of the text. This time, the word "sieh" (look) is highlighted as Christ asks Mary to look upon his wounds. With a few notable exceptions, the duration of the vocal pitches containing accented syllables throughout "Erlösung" are either longer or equal to those of the notes sounding unaccented syllables. In the second line of the second stanza, Christ breaks dramatically from the hitherto prosodic language into a speech-like exclamation as he explains the reason he must bear his wounds for all time. The first two words of the second line "die ich" (that I) make up an iambic poetic foot. The durational lengths of the notes sung at these words, however, consist of a quarter note followed by an eighth note. Webern set a longer durational pitch at the word "die" (that), a relative pronoun that refers back to the vital word "Wunden" (wounds) in the previous line. The phrase "für dein Sünd trag" (carry for thy sins) is set to two pairs of pitches, each note of the pair of equal durational lengths, reflecting the ambiguity of the poetic meter (fig. 4.3).

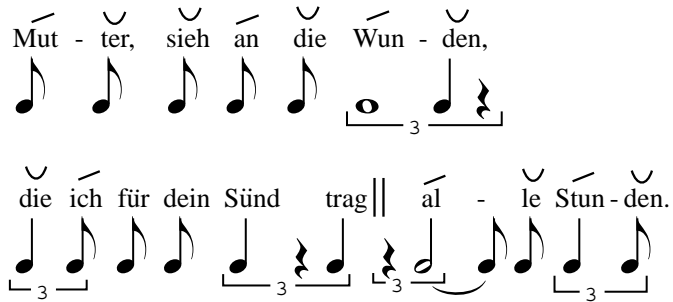

Fig. 4.3. Durational Lengths of the Vocal Pitches, Stanza Two, Lines 1-2

The third and fourth lines of the second stanza are set, with a single notable exception, in an alternating pattern of strong and weak beats when Christ beseeches God to allow that his wounds be a sacrifice for the sins of man. The declamatory phrase “laß dir die” (let thou) breaks from the metrical regularity, appropriately during Christ’s supplication to his father (fig. 4.4).

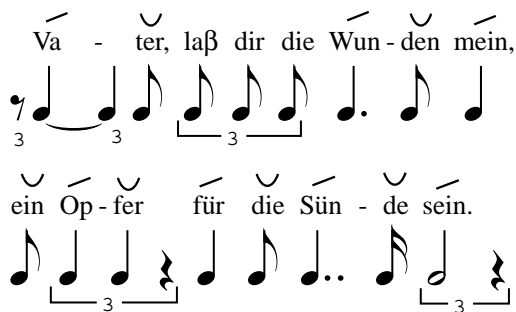

Fig. 4.4. Durational Lengths of the Vocal Pitches, Stanza Two, Lines 3-4

In the third stanza, God’s address to Christ at the phrase “Sohn, lieber Sohn mein” (Son, my beloved son) is marked by the accented word “Sohn” (son). This break from the strong-weak metrical pattern concluding the second stanza appropriately places strong emphasis on God’s address to Christ. Similar to the second stanza, the phrase “alles was du begehrt” (all that you wish for) presents unexpected durational lengths at the words “was du” (that you). The pitch duration at the metrically weak relative pronoun “was” (that) is longer than that of the word “du” (you). The emphasis accorded to the word “was” highlights its relation to the critical word

“alles” (all), an indicator that Christ’s wish will be granted in its entirety. The terse concluding phrase “das soll sein” (it shall come to pass) also places durational emphasis on a weak beat, this time at the word “soll” (shall). The extra length of this pitch heightens the sense of anticipation before the poem comes to a divine conclusion when God grants Christ his wish at the word “sein” (fig 4.5).

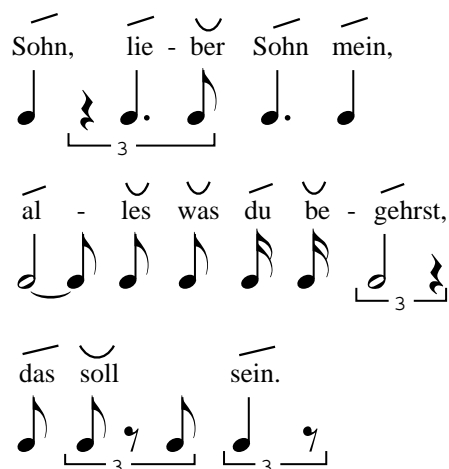

Fig. 4.5. Durational Lengths of the Vocal Pitches, Stanza Three

Op. 18, no. 2 is Webern’s first serial composition to feature varying row forms. As in Op. 18, no. 1, he continued to compose serially with harmonic row statements throughout “Erlösung.” Mary’s dialogue consists of seven consecutive P6 row statements (pickup beat-m. 5). Christ’s anguished response to Mary is expressed musically through eight I6 rows (mm. 6-10) followed by nine RI 6 rows when he implores God to grant him his wish (mm. 10-13), thus displaying a notable row rate increase. God’s proclamation, expressed through eight R6 row statements, presents a slight slowing down of the row rate, which leads to the song’s conclusion (mm. 14-18).

In contrast to Op. 18, no. 1, imbrications of the Op. 18, no. 2 row reveal that trichordal adjacencies consist almost exclusively of a single set.⁷⁸ Eight of the twelve row trichords are

⁷⁸Similar to the Op. 18, no. 1 row, “around-the-corner” set imbrications and intervals will be included in my discussion of the Op. 18, no. 2 row.

members of set 3-3, a phenomenon achieved by means of the row's intervallic makeup. Alternating 3 and 8 OPCIs sound pervasively throughout the row with three notable exceptions: the pattern is broken in the middle of the row at the two adjacent OPCIs 8s, at the final OPCIs 11, and at the "around-the-corner" OPCIs 6 (fig. 4.6).

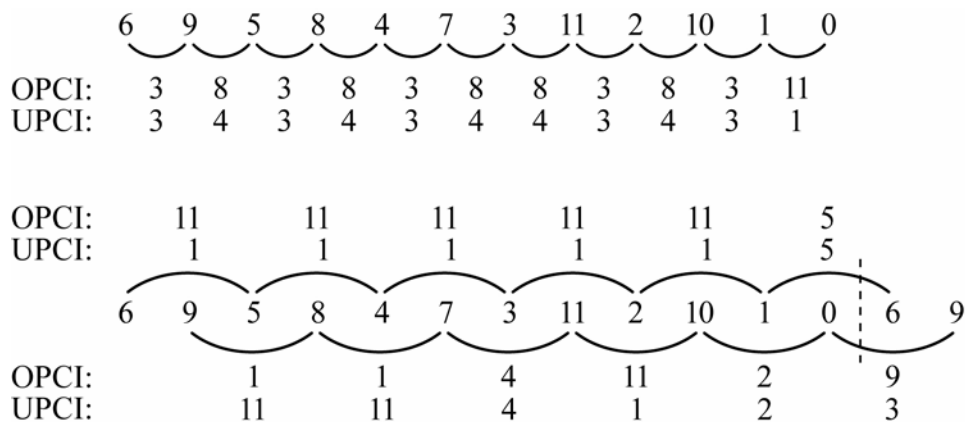

Fig. 4.6. "Erlösung" Row Intervals

Permutations of the prime row ordering result in altered layouts of the row intervals. Retrograde rows feature the octave counterparts to the prime row OPCIs in reverse order. Conversely, the inverted row form consists of prime row complementary pitch classes sounding in the identical succession as their prime-row complements. Retrograde inversion of the series generates a reversed ordering of the identical prime row OPCIs (fig. 4.7).

Neighboring row members separated by a single pitch class produce IC 1 eight out of twelve times throughout the row. The pungent sound of this interval is exploited extensively throughout the clarinet and vocal lines, both by the non-adjacent neighboring row members and more distantly removed row members. The row intervals separated by a single row pitch are utilized less frequently throughout the vocal part, its longer durational pitch values precluding this compositional effect. Contrastingly, the rapid note values of the clarinet produce numerous IC 1s built primarily by neighboring row members. IC 1 occurs extensively throughout the guitar chords as OPI 11, an interval that derives primarily from the row's non-adjacent

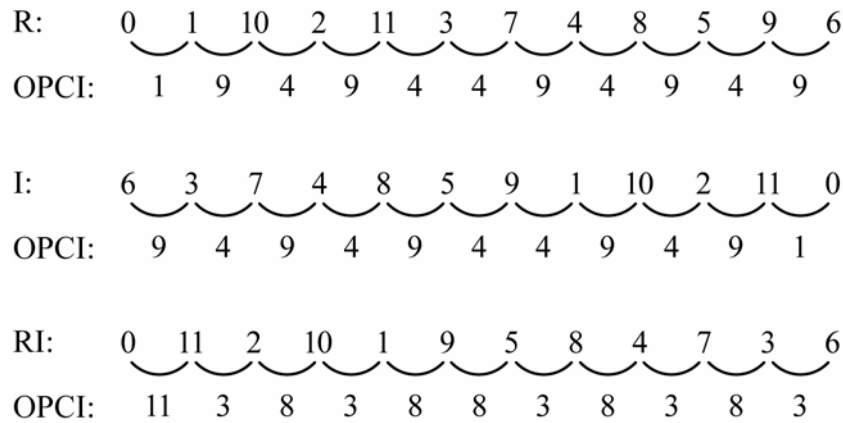

Fig. 4.7. Permutations of the Op. 18, no. 2 Row

neighboring IC 1s. The single IC 1 row adjacency is featured periodically as the outermost interval of the harmonic guitar chords. IC 1 is richly displayed throughout the vertical sonorities, the harmonic row statements positioning the row pitches in close proximity to one another.

The OPCIs 3 and 8 that imbue the Op. 18, no. 2 row sound infrequently throughout the melodic lines. As in Op. 18, no. 1, the harmonic row statements prevent pervasive row adjacencies from occurring in the melodic lines. UPI 3 is stated periodically throughout the vocal line, mostly by distantly-removed row members. The interval is displayed primarily as UPI 3 and is frequently juxtaposed with compound versions of IC 1. Intermittent statements of OPCI 8 sound in the vocal line, twice as row adjacencies and four times as distantly removed row members. The rapid execution of the clarinet line allows ICs 3 and 4 to surface occasionally as row adjacencies, most audibly in the solo row melodies that frame the beginning and ending of “Erlösung.” The intervallic size of the row’s OPCIs 3 and 8 are preserved in both melodies. Additional statements of ICs 3 and 4, formed primarily as UPIs 3 and 8, are sprinkled throughout the melodic lines of the clarinet. ICs 3 and 4 are frequently articulated together throughout the harmonic trichords of the guitar part as UPIs 3 and 8. In addition, ICs 3 and 4 recur throughout the vertical sonorities of “Erlösung” in a diverse array of intervallic formations.

In addition to 3-3, the larger row set imbrications display an aural consistency similar to that of Op. 18, no. 1. The intervallic makeup of the row yields alternating statements of tetrachords 4-3 and 4-7. The prime row of each set, (0134) and (0145) respectively, reveals an

underlying similarity between the two sonorities, the addition of a semitone at the second interval differentiating the two. A breach of the alternating interval pattern at the adjacent OPCI 8s results in consecutive formations of 4-19, a set that richly displays IC 4. Set 5-3 sounds four times throughout the pentachordal imbrications, its (01245) prime form showcasing a dense chromaticism. The intervallic adjacency of the OPCI 8s also produces two sequential statements of set 6-Z44, its 6-Z19 complement occurring twice as “around-the corner” sets. Hexachord 6-15, recurring four times throughout the row, is a set whose 323421 IC vector closely resembles the 313431 IC vector of sets 6-Z44 and 6-Z19. In addition, Z-related sets 6-Z4 and 6-Z37 occur within the row. The chromatic 6-1 sounds both at the beginning and at the halfway point of the row, producing a pair of combinatorial sets related by means of T_6 .

The intervals outlined in the instrumental introduction hint at the intervallic influx that will come to define the musical material of “Erlösung.” The clarinet’s dramatic OPI -21 descent, an interval whose initial *sf* pitch is followed by a pitch contrastingly articulated at a *p* dynamic level, sounds in stark contrast to the serene beginning of “Schatzerl klein.” From this opening interval, the clarinet unfolds a melody built from a chain of rapidly alternating OPIS +3 and +8, creating parallel [3][8] trichordal formations (pickup beat) (fig. 4.8).

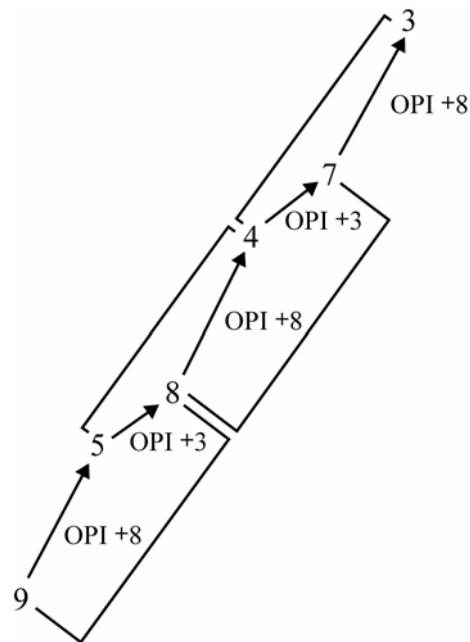

Fig. 4.8. Opening Clarinet Melody

The introductory clarinet melody concludes with a pointillistic descent of OPI -13, each pitch executed at a *fp* dynamic level followed by a *crescendo*. This contrasting blend of smaller and larger intervals points to latter intervallic unfoldings in “Erlösung.”

The two opening guitar trichords, [3][11] and [6][11], are unfoldings of [3][8] and [5][6] respectively, basic forms that will recur throughout the harmonic guitar trichords. Each trichord is executed as an ascending figure, the tremolo articulation of the first two notes at a *fp* dynamic level followed by a *crescendo* leading to a *sf staccato* pitch. The colorful ascent of each figure anticipates the dramatic tension that will unfold throughout the “Erlösung” text (m. 1). The guitar figure overlapping the phrases “Mein Kind” (my child) and “sieh an die” (look upon the) articulates trichord [3][8] followed by an imbricated [8][11], the intervallic expansion suggesting the mounting of dramatic tension (m. 2, bt. 1) (fig. 4.9).

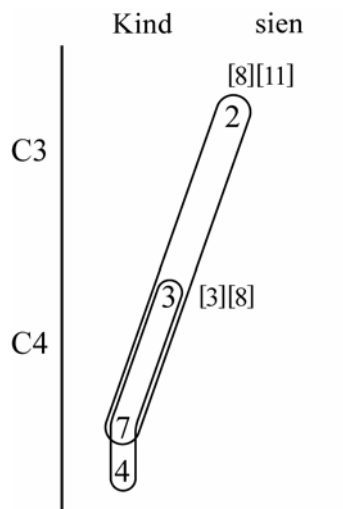

Fig. 4.9. Guitar Trichords, m. 2, bt. 1

The diverse intervallic formations outlined in the first poetic couplet highlight Mary’s message of hope as well as the impending dramatic conflict that will unfold throughout Christ’s dialogue. The vocal line commences with Mary’s address to Christ at the phrase “Mein Kind” (my child), both words articulating loud G#5s sounding in marked contrast to the gentle melodic opening of “Schatzerl klein” (mm. 1-2). The repeated notes evoke an insistent tone as Mary

entreats Christ to look upon her as a comforting figure. The mirror symmetry of the [11][5][11] vertical intervallic formation built on the word “die” (the) provides a contrastingly placid regularity to the song’s opening (m. 2, bt. 2). Above this, the voice forms a compact [3][8] trichord on the words “sie an die” (look upon my), a reduction of the previous intervallic span. The subsequent phrase, “die Brüste mein” (my breast) commences with a [3][11] trichord followed by a melismatic OPI -13 on the word “mein” (mine) (m. 3). This intervallic enlargement leads to the C#6 that begins the second poetic line “kein Sünder” (no sinners), the second-highest vocal pitch of “Erlösung” (m. 3, bt. 2). Mary’s soothing assurance that she will divert sinners from sin is undercut by this note sounding beyond the soprano tessitura. A steep OPI +23 separates the phrase “die Brüste mein” (my breast) with that of the words “kein Sünder” (no sinners), the second-largest intervallic vocal leap to appear in “Erlösung.” The resultant tension-filled sound augurs Christ’s latter response to his mother, in which he attributes his wounds to her sin.

Both the guitar and the clarinet mirror the contradictory moods of the first stanza: Mary’s optimistic dialogue and the foreboding of Christ’s sorrowful dialogue. The guitar accompaniment framing the “sieh an die Brüste mein” (look upon my breast) consists primarily of UPI 11s connected by smaller intervals ranging in size from UPI 2 to UPI 9 (m. 2, bt. 2-m. 3). The phrase “kein Sünder” (no sinners) is contrastingly articulated as a pair of melodic OPI +11s that stem from a compact harmonic UPI 6 (m. 3, bt. 2-m. 4, bt. 1). These intervals are played at a *ff* dynamic level, the first time the dynamic level exceeds a *f*. The clarinet sounds a compact [5][6] trichord at the words “Brüste mein” (my breast), followed by a large OPI +25 ascent that precedes the closing phrase “laß verloren sein” (let be lost) (m. 3, m. 4, bt. 2). A subsequent OPI +11 marks the close of Mary’s dialogue, its reduced intervallic span echoed by the guitar harmonies. The first stanza concludes with a series of guitar UPI 11s at the phrase “laß verloren sein” (let be lost) among which UPIs [3][8] and [5][6] are formed, a compressed intervallic presentation of the opening intervals (m. 4, bt. 2-m. 5). The guitar accompaniment thus emerges as a musical denouement marking the close of Mary’s dialogue (fig. 4. 10).

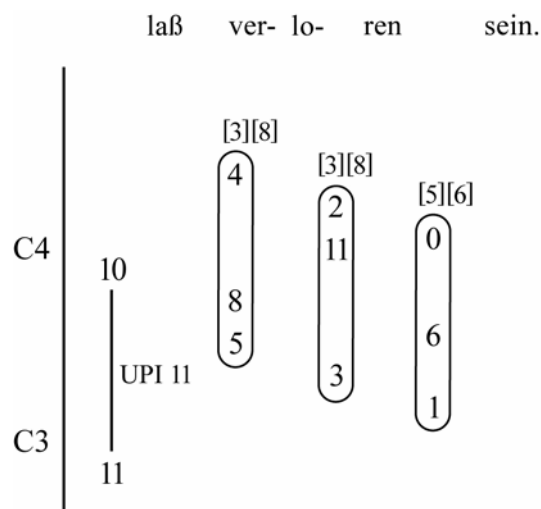

Fig. 4.10. Guitar Intervals, m. 4, bt. 2-m. 5, bt. 1

In addition, the harmonic UPI 11s link the rhyming of the second and fourth poetic lines, a sound of soothing familiarity that accompanies Mary’s reassuring message. Following the end of the vocal line, the clarinet forms a chain of descending [4][9] trichords that concludes with an ascending OPI +13. The recurring clarinet melody thus presents an intervallic expansion of the opening melody in anticipation of the dramatic tension that will unfold (m. 5).

A [3][8] constellation forms at the phrase “Mutter, sieh an die Wunden” (mother, look upon the wounds) along with UPCI 1s and [5][6] in shaping Christ’s plaintive response to Mary. The vocal line articulates two OPI -11s followed by an ascending OPI +13 at the words “Mutter, sieh an die” (mother, look upon) (m. 6). The rising UPCI 1 motif returns in the guitar accompaniment beneath the word “Mutter” (mother), this time as two consecutive OPI +13s (m. 6, bt. 1). These larger UPCI 1 formations anticipate the word “Wunden” (wounds) when Christ displays his wounds caused by Mary’s original sin. A harmonic tetrachord subsequently sounds beneath the word “sieh” (look) a sonority conjoined with the previous pitch in building imbricated [3][11] and [3][5] trichords beneath which [5][6] is also articulated. The following trichord forms [3][8], the resultant basic form that is reiterated twice as a *sf* chord beneath the word “Wunden” (wounds) (m. 7) (fig. 4.11).

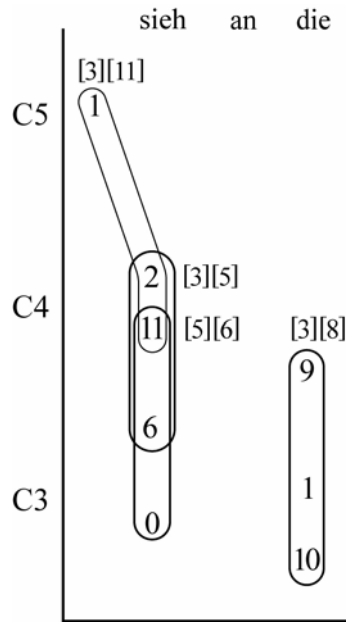

Fig. 4.11. Guitar Trichords, m. 6, bt. 2

The clarinet melody accompanies the word “Wunden” (wounds) with two identical melodies in which trichords [3][8] and [8][11] shape the melodic descent, a further reinforcement of the prominent [3][8] vocal trichord.

The poetic line “die ich für dein Sünd trag alle Stunden” (that I carry every hour for thy sins) presents a vivid musical realization of the intervallic material introduced in the first part of the song. Appearing amongst a dense progression of [3][8] harmonic trichords at this phrase is a second guitar tetrachord built from imbricated trichords [3][8] and [5][8], the latter spanning UPI 13, an expansion of the previous tetrachord (m. 8, bt. 2). The guitar sounds a novel [4][7] trichord beneath the word “für” (for) preceding the word “Sünd” (sin) (m. 8, bt. 2) (fig. 4.12). Two large OPI -23 clarinet intervals accompany the phrase “alle Stunden” (every hour) a consecutive pair of OPI -23s that underscore the extent to which Christ has been wounded (m. 9). Trichord [3][8] recurs at the vocal phrase “alle Stunden” (every hour) in marking the close of the stanza (m. 9). The repeated vocal [3][8] trichord reinforces the rhyming of the words “Wunden” and “Stunden.”

Christ’s subsequent dialogue features the highest registral pitches of the voice and clarinet as well as the largest intervallic clarinet leap. His address to his father at the word

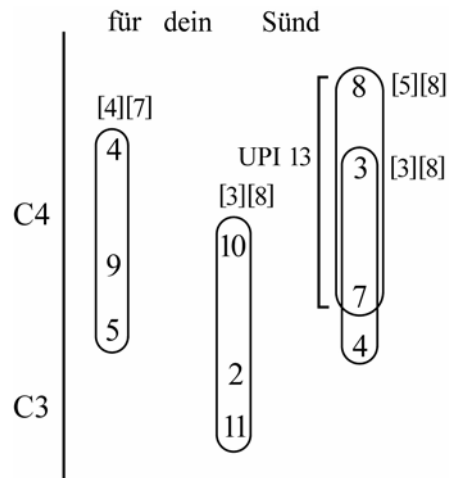

Fig. 4.12. Guitar Trichords, m. 8, bt. 2

“Vater” (father) commences on D6, the registral vocal acme of “Erlösung.” The extreme height of this pitch highlights Christ’s anguish as he approaches God with his self-effacing request. The clarinet accompanies the voice with B6, also presenting its highest registral pitch (m. 10, bt. 1). Both pitches are executed at a *ff* dynamic level, the first time either part has exceeded a *f* level. The *etwas breiter* (somewhat broader) tempo of these pitches, a contrast from the previous *ritardando* ending of the first couplet, further accentuates their registral heights. Large UPI vocal intervals are formed at the beginning of this stanza in underscoring Christ’s impassioned dialogue: OPI -13 at the word “Vater” (father) followed by two consecutive OPI -13s at the words “dir die Wunden” (Thou my wounds) (mm. 10, bt. 2-m. 11, bt. 1). The OPI +35 clarinet leap from G#3 to G6 at the word “Sünde” (sin) represents the largest interval of the clarinet part (mm. 12-13). Its large span suggests the enormous burden of sin Christ will accept in exchange for man’s redemption. In addition, a dense [5][6] guitar constellation coincides with the second utterance of the word “Wunden” (wounds) (m. 10, bt. 2-m. 11, bt. 1) (fig. 4.13). The stanza concludes with two imbricated [11][14] trichords at the phrase “für die Sünde sein” (for sin), the second-order derivative of [3][8] that recalls the conclusion of the previous poetic couplet (mm. 12-13). The conclusion of the phrase “laß dir die Wunden mein” (let Thou my wounds) is marked by a contrasting guitar figure: an accented four-pitch guitar melody that articulates OPI -13 followed by OPIs -11 and +11 respectively (m. 11, bt. 2).

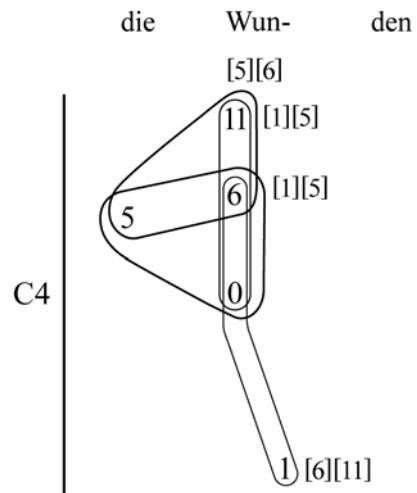

Fig. 4. 13. Guitar Constellation [5][6], m. 10, bt. 2-m. 11

The voice commences the final poetic couplet with an OPI +25, the largest vocal intervallic leap of “Erlösung,” formed between the words “Sohn” (son) and “lieber” (dear) (mm. 14-15). This expansive interval sounds as a focal point that underscores the absolute power of God. Trichord [3][8] concludes God’s address to Christ at the endearing words “lieber Sohn mein” (dear son of mine), a notable decrease of intervallic size evoking God’s tender feelings towards his son (mm. 14-15). Following an OPI -11 descent at the word “alles” (all), both [3][8] outfoldings, [3][11] and [8][11], sound at the phrase “was du begehrt” (that you wish for) as a realization of that which Christ will soon attain (m. 16).

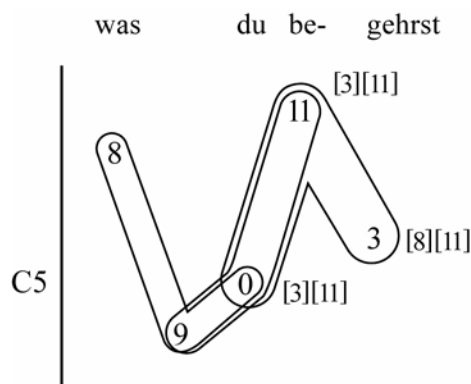

Fig. 4.14. Vocal [3][8] Trichordal Outfoldings, m. 16

The clarinet precedes the opening of the final stanza with a hushed [5][6] trichord, its final pitch sustaining over God’s gentle address to Christ at the word “Sohn” (son) (m. 13, bt. 2-m. 14, bt. 1). Following a sharp OPI +23 ascent at the repeated word “Sohn,” the clarinet concludes the phrase “Sohn, lieber Sohn mein” (son, dear son of mine) with trichord [6][11], an unfolding of the [5][6] trichord that commences the final stanza (m. 15). Clarinet intervals OPI -23 and -20 frame the word “alles” (all), decisive descents that draw further attention to the word (m. 16) (fig. 4.15).

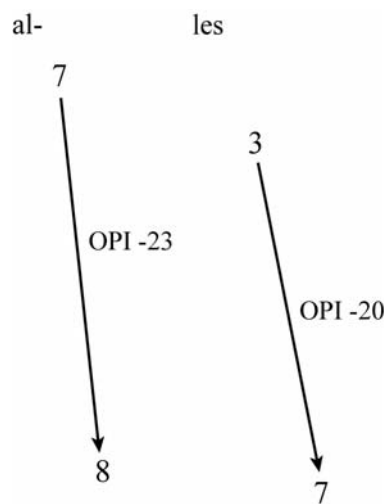

Fig. 4.15. Clarinet Intervals, m. 16

The solo postludal clarinet melody articulates a figure that closely resembles the opening melody: a chain of descending [3][8] trichords following the initial [3][6] that end with an ascending OPI +21. The final clarinet interval, whose arrival pitch is executed at a *fff* dynamic level, suggests unresolved dramatic tension as Christ now bears the sins of humanity.

Guitar trichord [4][7] recurs in marking pivotal moments of the final two poetic couplets of “Erlösung.” The trichord sounds beneath the word “Opfer” (sacrifice), a harmonic [4][7] followed by an imbricated [7][11] formed with the following pitch (m. 12, bt. 1). The trichord re-emerges to mark the end of Christ’s discourse beneath the word “sein” (be), followed by a softly-executed [4][7] trichord, the first pitch played as a tremolo figure, that accompanies God’s

address to Christ at the word “Sohn” (son) (m. 14, bt. 1). A link between the two poetic couplets is thus formed: the suffering Christ figure connected to that of his father. The word “alles” (all) commences with a harmonic [4][7] trichord followed by a rich web of [5][6] and [3][8] formations that herald the salvation of man (m. 16) (fig. 4.16).

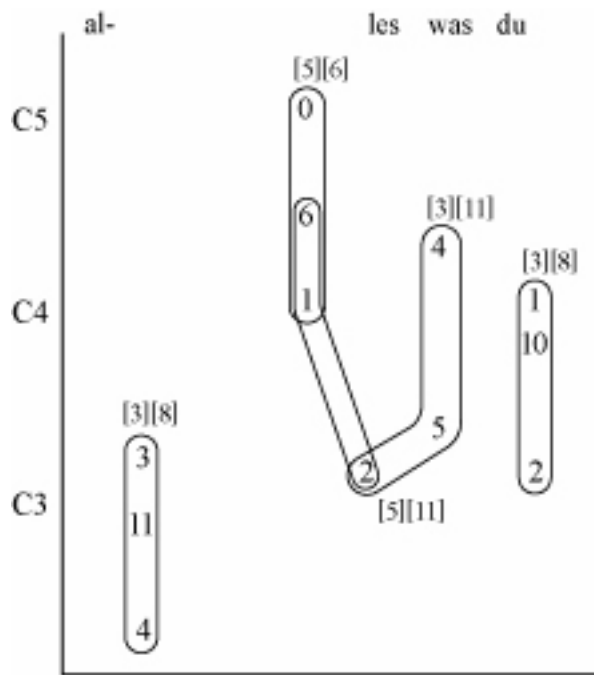

Fig. 4.16. Guitar Trichords, m. 16

A final [4][7] overlaps the word “das” (that) in underscoring God’s affirmative proclamation that Christ will be granted his wish (m. 16). The last tetrachord, an imbricated pair of [5][8] and [3][8] trichords executed as an accented *ff* chord, accompanies the word “sein,” the concluding word of the phrase “das soll sein” (it shall come to pass) (m. 18). This tetrachord echoes the identical chord sounding at the word “Sünd” (sins) as a reminder that Christ will now serve as a martyr for the sins of humanity (fig. 4.17).

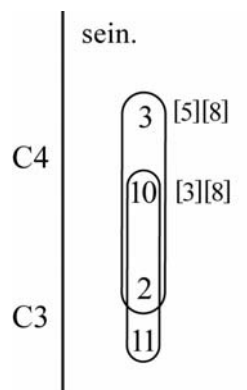

Fig. 4.17. Guitar Tetrachord, m. 18

A series of chromatic sets characterize the opening of “Erlösung,” their dense pitch compaction foreshadowing the intense religious dialogue that will take place among the three divine figures. The brief instrumental introduction of “Erlösung” is dramatically initiated by a rapidly executed, ascending clarinet melody that articulates septachord 7-1 (pickup beat). The merging of this set with the ensuing pointillistic clarinet pitches builds octachord 8-1 (pickup beat-m.1). The initial vocal phrase “Mein Kind, sieh an die Brüste mein” (My child, look upon my breast) also forms octachord 8-1 (mm. 1-3). Similar to the opening clarinet melody, a prominent 7-1 set sounds at the phrase “sieh an die Brüste mein,” a subset separated from its initial melodic pitch by a brief intervening rest. With the exception of the A4 occurring at the word “die” (the) (m. 2, bt. 2), the remaining pitches are built from non-consecutive row adjacencies. The guitar supports the chromatic vocal line by articulating nonachord 9-1, a phrase that commences in a contrastingly low register (m. 1-m. 2, bt. 1). The vocal phrase “Mein Kind, sieh an die” (My child, look upon my) blends with the accompanying clarinet melody in forming hexachord 6-1, a further emphasis of the chromatic sound (m. 2).

Chromatic sets surface throughout “Erlösung” as the divine characters address one another before launching into their religious dialogue. In a parallel manner, the beginning of Christ’s dialogue is marked by a cluster of chromatic sets. The three parts form septachord 7-1 at the word “Mutter” (mother) when Christ addresses Mary (m. 6, bt. 1). The voice and guitar create an additional chromatic set: hexachord 6-1 (m. 6, bt. 1). Nonachord 9-1 is subsequently articulated by the instrumental accompaniment over which trichord 3-1 sounds at the vocal

phrase “sieh an die” (look upon the) (m. 16, bt. 2). A 4-1 clarinet melody overlaps with the word “Mutter” (mother) and the phrase “sie an die” (look upon the), the only other exclusively chromatic set found in the clarinet line (m. 6). Christ’s address to God similarly produces 5-1, a set formed by all three parts at the word “Vater” (father) (m. 10, bt. 1). A subsequent instrumental 7-1 is built by both instruments during the momentary vocal rest (m. 10, bt. 2).

The expectant chromaticism is slightly delayed in the fourth poetic couplet during which God responds to Christ’s entreaty, his word providing dramatic resolution to the “Erlösung” poem. This musical suspension heightens the sense of anticipation as Christ awaits his father’s response. The voice and guitar parts form 9-1 on the word “alles” (all) as God grants Christ his wish (m. 16). The arrival on this word is further enhanced by the length of the first syllable which sustains for the duration of a half note and eighth note combined as the longest vocal pitch to sound throughout “Erlösung.” In addition, the guitar phrase accompanying the proclamation “alles was du begehrt” (all that you wish for) articulates nonachord 9-1 (m. 16). A simultaneous 6-1 is built by the melodic guitar pitches at this phrase (m. 16).

Trichord 3-5, a set that occurs only once in the row as an “around-the-corner” set, emerges at the phrases “ein Opfer” (a sacrifice) and “das soll sein” (it shall come to pass) (mm. 11-12, mm. 17-18). Jesus’s desire that his wounds be a sacrifice for the sins of man is thus recalled at the concluding proclamation. Following the words “ein Opfer” (a sacrifice), a 9-5 clarinet melody extends over the phrase “für die Sünde sein” (for sin), thereby associating Christ’s sacrifice with mankind (m. 12, bt. 2-m. 13). Complementary set 9-5 is formed by all three voices on the word “alles” (all) as a harbinger of God’s word (m. 16). In addition, trichord 3-5 sounds at the words “ich für dein” (I for thy) during which Christ attributes his wounds to the sins of his mother as a descendant of Eve (m. 8). Christ’s wounds are thus linked aurally to his ultimate sacrifice for humanity. The instrumental accompaniment spanning the words “die ich für dein” (that I for thy) forms complementary nonachord 9-5, further reinforcing the trichordal vocal set (m. 8, bt. 1).

Octachord 8-7 recurs periodically in highlighting the dramatic conflict that unfolds throughout “Erlösung.” The octachord encompasses the phrase “kein Sünder” (no sinners), as a set built from all three parts, in which Mary assures Christ that her being serves as a beacon for mankind (mm. 3-4). The set appears once again at the word “Wunden” (wounds), a sonority

formed by all three parts (m. 7). Mary's assurance that she will lead sinners away from temptation is thereby juxtaposed against the image of Christ's wounds (m. 7). The final syllable of the word "Opfer" (sacrifice) sustains over the instrumental accompaniment in forming octachord 8-7 (m. 12, bt. 1). Christ's sacrifice is thus connected to the image of his wounds. The extent to which he has sacrificed for humanity is emphasized by means of this set association: the grisly image of his wounds recalled when he proffers himself as a martyr for mankind. Octachord 8-7 resurfaces at the closing word "sein" (come to pass), a set built by the voice and the clarinet as the word of God brings the song to its dramatic conclusion (m. 21). The recurring set emerges to link the various narrative strands of "Erlösung." Mary's assertion that her divine being will guide humanity from sin is undercut by Christ's revealing of his wounds inflicted by female sin. His desire that they serve as a sacrifice for mankind is then granted by God at the end of "Erlösung."

A series of 3-3 trichords surface throughout "Erlösung" as clarinet melodies that demarcate text subsections. At the opening of the brief instrumental introduction, the unaccompanied clarinet melody articulates a series of 3-3 sets deriving from adjacent row members (pickup beat). A similar clarinet melody built primarily from row adjacencies unfolds at the close of Mary's dialogue: a series of 3-3 sets in which a single 3-10 is interjected as the second-to-last set (m. 5). Harmonic guitar trichord 3-3 sounds at the end of this melody, a further reinforcement of the recurring row set. A solo clarinet melody initiated by set 3-10 occurs once again in the brief instrumental postlude as an audible repeated motif (m. 21).

Complementary set pair 3-3/9-3 appears throughout "Erlösung" in marking contrasting ideas of the poetic text. Vocal trichord 3-3 sounds both at the phrase "sieh an die" (look upon my) and the word "verloren" (lost), creating two contrasting images of man: the first in which he gazes towards Mary's divine figure and the second of his becoming disoriented by his sin (m. 2, mm. 4-5). The instrumental accompaniment framing the words "Kind, sieh an die" (child, look upon) forms complementary set 9-3 as a reinforcement of the vocal text (m. 2). Nonachord 9-3 is also built by the voice and guitar material spanning the phrase "laß verloren sein" (let be lost) (m. 4, bt. 2-m. 5, bt. 1). Trichord 3-3 recurs at the phrase "laß dir die" (let thou my) as Christ implores God to allow that his wounds be a sacrifice in helping man gain redemption (m. 10, bt. 2). The *f* dynamic level and accent markings sounding over each vocal pitch further emphasize

Christ's impassioned state as he pleads with God for the salvation of man. The phrase "lieber Sohn" (dear son) also forms set 3-3, a set whose contrasting *zart* (tender) performance marking foreshadows God's subsequent granting of Christ's wish (mm. 14-15). Once again, trichord 3-3 highlights a notable textual contrast, this time pointing out a difference between Christ's anguished state and the soothing reply of his father. Nonachord 9-3 is built by all three parts as the larger complementary set spanning each vocal phrase (m. 10, bt. 2; mm. 14-15).

Set 3-4, a set that does not occur in the row, recurs sporadically throughout the vocal line in drawing additional textual associations. The set initially sounds at the phrase "kein Sünder" (no sinners) as Mary implores Christ to gaze upon her breast (m. 2). Trichord 3-4 is repeated at the ascent of the word "Wunden" (wounds), during which Christ shows Mary the wounds she has inflicted on him because of her sin (m. 7). The vivid image of Mary's physical being is thereby set against that of a wounded Christ. The final trichord subset of the phrase "Wunden mein" (my wounds) forms 3-4, this time as Christ turns towards God to plead for mankind. As with octachord 8-7, trichord 3-4 connects the divine figures of Mary, Christ, and God with one another, conjuring a distinct image of the three contrasting protagonists.

The contours of Op. 18, no. 2 reflect the direct intensity of the religious dialogue that takes place throughout the "Erlösung" text (fig. 4.18). In the first part of the poem, contour <2031> sounds as the prime form of the initial clarinet melody, its abrupt changes of direction highlighted by a lack of registrally adjacent contour pitches (pickup beat-m. 1). The occurrence of the jagged contour in the brief instrumental introduction foreshadows its use at key phrases of the text to aurally depict Mary's sin. The prime form of contour <2031> is immediately repeated by the voice at the beginning of the poem as Mary implores Christ to gaze upon her breast (mm. 1-3). Significantly, the contour appears again as the prime form of the fragmented vocal phrase "die ich für dein Sünd trag alle Stunden" (that I carry every hour for thy sins) (mm. 8-9). The figure of Mary as an embodiment of femininity is thereby juxtaposed against Christ's assertion that his wounds were brought on by her sins. The prime form of contour <2031> occurs a third time in the vocal part at the phrase "alles, was du begehrt" (all that you wish for), a reference to Christ's desire that his wounds be a sacrifice for the sins of the world (mm. 16-17). The clarinet precedes the voice's final sounding of <2031> with three consecutive prime statements of the contour (mm. 12, bt. 2-m. 15), two accompanying the phrase "für die Sünde sein" (for sin), and

the third at the phrase “Sohn, lieber Sohn mein” (Son, my beloved son). Vocal contour <1302>, the retrograde of <2031> formed at the phrase “für die Sünde sein” serves as a further reminder of the Original Sin inflicted by Eve. The guitar’s utterance of <1302> as a prime form beneath the vocal phrase that concludes Christ’s dialogue with God also sounds along with the word “Vater” as a four-note contour (m. 10, bt. 1) at the beginning of the dialogue.

Fragmentary guitar gestures support the vocal contours throughout Mary’s dialogue, a role the clarinet also reverts to following its dramatic opening melody. The ascent of the vocal phrase “sieh an die” (look upon the) (m. 2) is foreshadowed by the guitar’s two-note motifs sounding in the instrumental introduction and the three-note figure that overlaps its initial pitch. In contrast to the primary use of the descending figure in “Schatzerl klein” as a concluding gesture, the <210> motif is sung by the voice at the words “kein Sünder” (no sinner) as the centerpiece of Mary’s dialogue (mm. 3-4). The <210> vocal contour is anticipated by the identical clarinet figure in measure three. Mary’s brief concluding phrase “laß verloren sein” (let be lost) recalls the beginning <2031> contour as a subcontour formed on its final four pitches, thus emphasizing the rhyming couplet of the first two poetic lines (mm. 4-5). The clarinet foreshadows this contour as a subsegment of a five-pitch melody, contrastingly formed on its first four pitches. Fractional, two-note guitar figures trace the dramatic rise and fall of these two final contours (mm. 4-5). Throughout “Erlösung,” the guitar continues this trend of playing brief gestures that shadow the melodic contours of the voice and clarinet.

In the second part of the poem, Christ implores Mary to look upon his wounds, a vocal phrase dramatically marked by <102>, a contour whose final ascent moves steeply from its lowest to its highest contour pitch (mm. 6-7). Paradoxically, the clarinet and guitar both produce <021> at the beginning of measure six, a contour whose final descent sounds in stark contrast to the final ascent of <102> (fig. 4.19). Contour <102> sounds both at the words “sieh an die” (look upon the), a phrase followed by the sharp rise of <012> on the word “Wunden” (wounds), and as a prime form over the span of the vocal phrase “Mutter, sieh an die Wunden” (mm. 6-7) (fig. 4.20).

clarinet (pickup beat - m. 1):

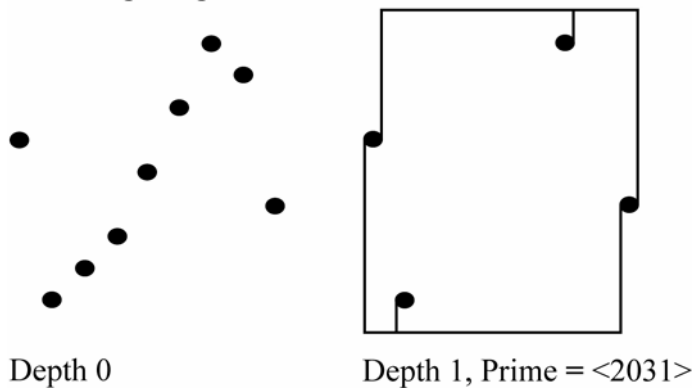

voice (mm. 1-3):

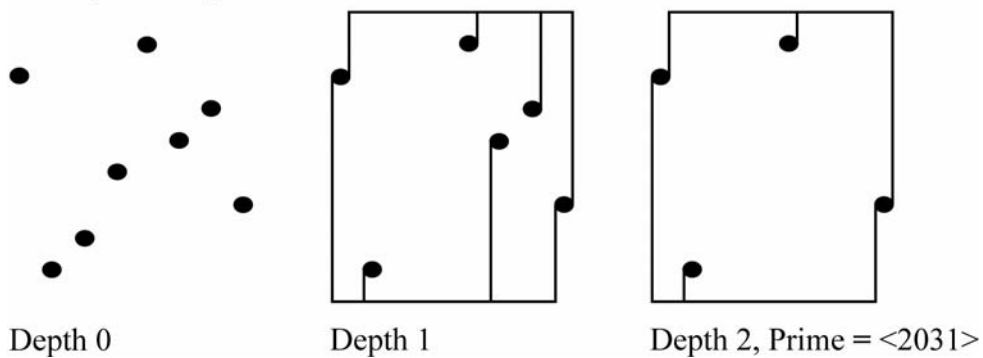

voice (mm. 8-9):

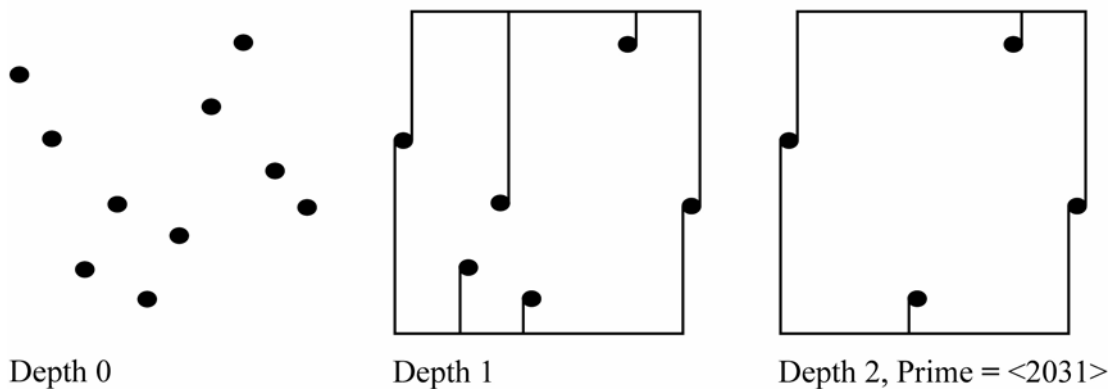
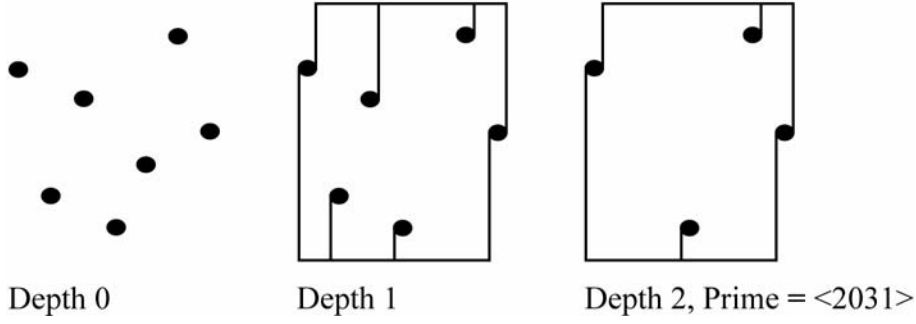
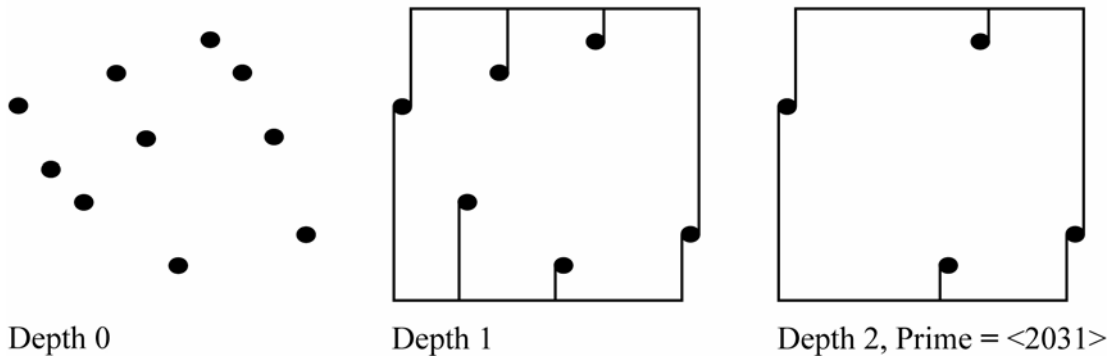

Fig. 4.18. Contours <2031> and <1302>

voice (mm. 16-17):



clarinet (mm. 12-13):



clarinet (m. 13):

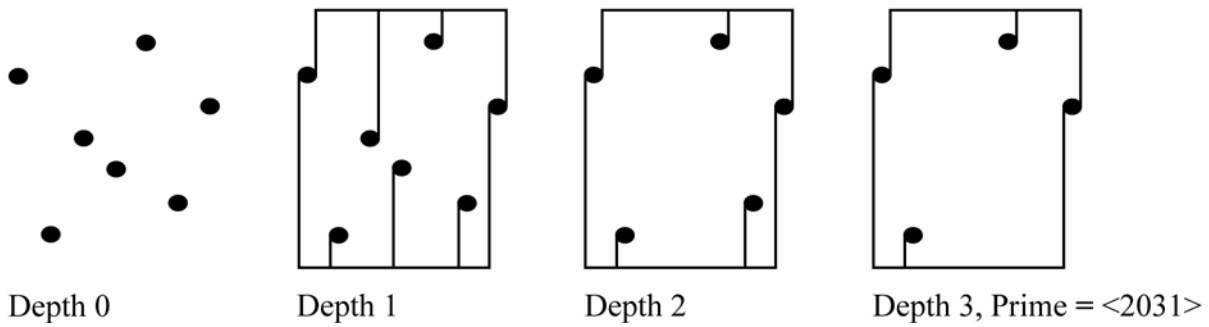
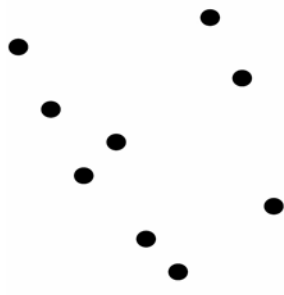
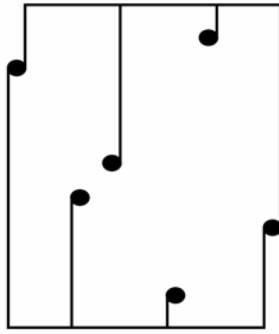

Fig. 4.18. Contours <2031> and <1302> (continued)

clarinet (mm. 13-15):



Depth 0



Depth 1

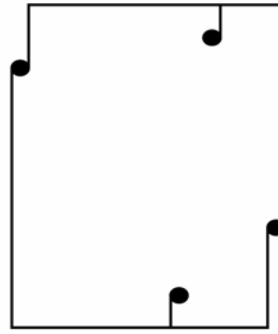

Depth 2, Prime = <2031>

guitar (mm. 12-13):

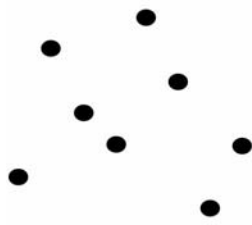

Depth 0

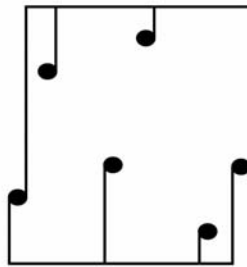

Depth 1

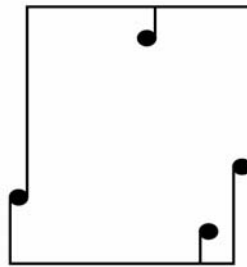

Depth 2, Prime = <1302>

Fig. 4.18. Contours <2031> and <1302> (continued)

clarinet:

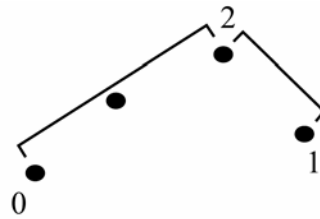

guitar:

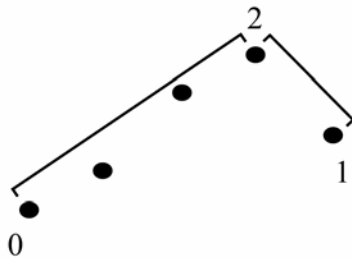
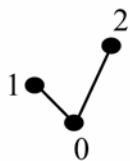

Fig. 4.19. Contour <021>, m. 6

voice (m. 6, bt. 2):



and
mm. 6-7:

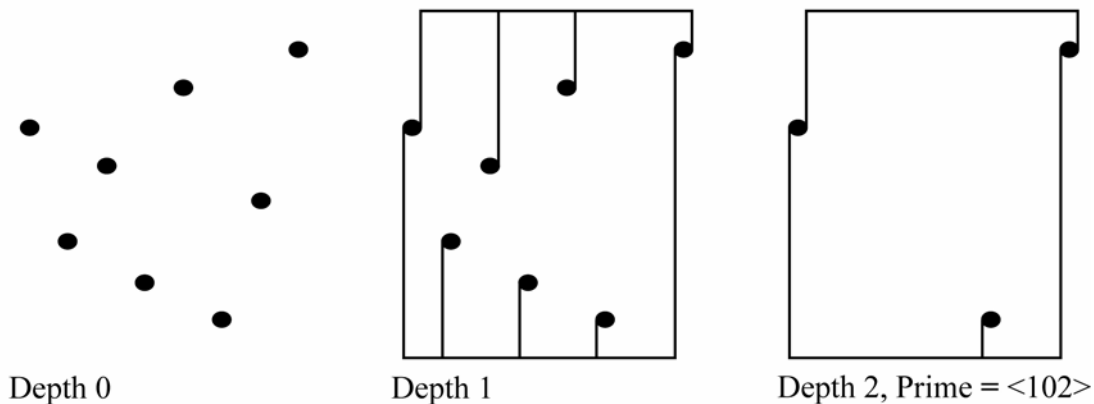

Fig. 4.20. Voice Contour <102>, mm. 6-7

The clarinet produces contour <102> as a prime form emerging from a large group of pitches, its final pitch played in the subsequent vocal phrase (mm. 6-8) (fig. 4.21).

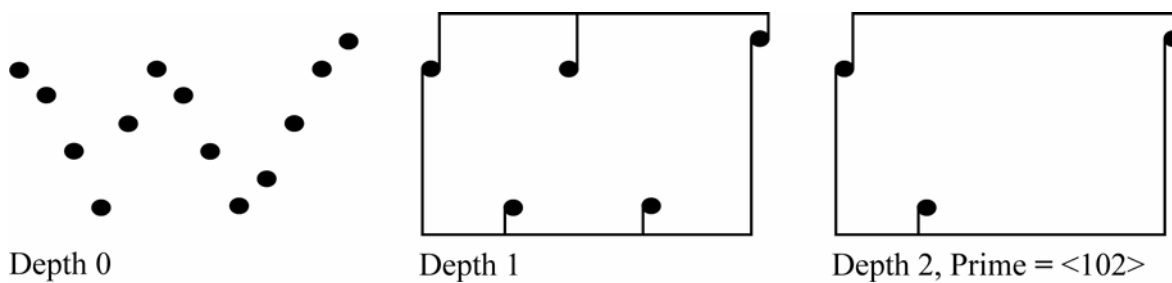

Fig. 4.21. Clarinet Contour <102>, mm. 6-8

The intense sounds of both <102> and <012>, the contours that portray the infliction of Christ's wounds, are prefigured throughout Mary's dialogue. Prior to the entrance of the voice,

contour <102> is articulated from the salient registral points of the clarinet’s rapid sixteenth-note figure played at the pickup beat. The guitar reiterates the contour beneath the words “sieh an die” (look upon the) as Mary entreats Christ to gaze upon her breast (m. 2, bt. 2). Similar to the vocal contours in measures six and seven, guitar subcontour <102> sounds beneath the words “an die” before merging with its subsequent musical material in creating a prime form of the contour (mm. 2-4) (fig. 4.22).

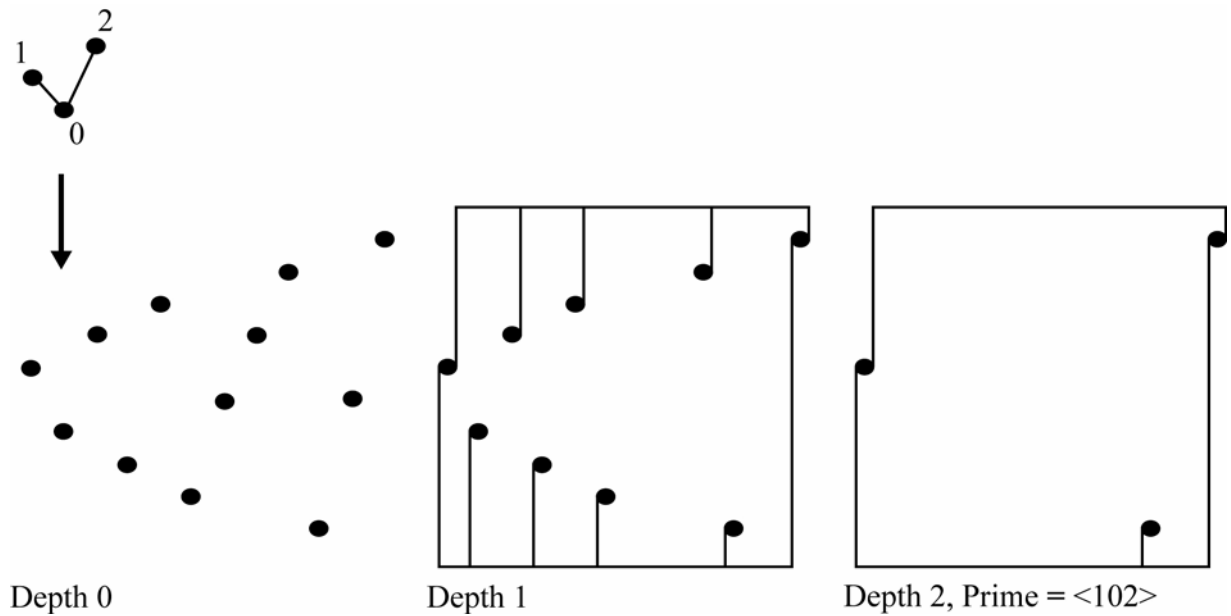

Fig. 4.22. Guitar Contour <102>, mm. 2-4

The final three pitches of the large guitar phrase forcefully anticipate vocal contour <012> at a *ff* dynamic level beneath the word “Sünder” (sinners), a reminder that Christ’s wounds were inflicted by the sins of Eve (m. 4, bt. 1).

Fragmentary clarinet subcontours that sound beneath the phrase “die ich für dein Sünd trag alle Stunden” (that I carry every hour for thy sins) echo prime vocal contour <2031> (mm. 8-9), thus underscoring the import of Christ’s words. Clarinet contour <021> accompanies the word “trag” (carry), a subcontour of <2031> formed on its final three contour pitches, that precedes the conclusion of the large vocal contour (mm. 8-9) (fig. 4.23).

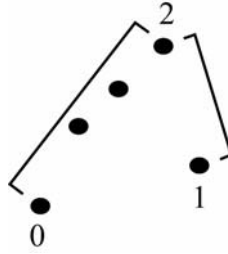

Fig. 4.23. Clarinet Subcontour <021>, mm. 8-9

The subsequent execution of the clarinet's two-note descending figure at a *fp* dynamic level that crescendos to a *fff* coincides with the concluding descent of the vocal line at the words "alle Stunden" (every hour). This emphatic presentation of the clarinet figure, along with the vocal conclusion of the phrase, highlights the lasting impact of Christ's wounds (m. 9). In contrast, the musical arrangement of the guitar material beneath the phrase "die ich für dein Sünd trag" (that I carry for thy sins) mirrors the fragmentary setting of the metrically ambiguous poetic line. A clear formation of contours, or lack of them, is difficult to establish among these sonorities (m. 8). The frequent interjection of eighth-note rests, coupled with dynamic and rhythmic shifting, contribute to this sense of musical uncertainty. In the following measure, the guitar sounds a distinct <3201> contour beneath the beginning of the metrically clear-cut phrase "alle Stunden" (every hour) (m. 9, bt. 1). The poetic restoration of an unequivocal metrical scheme thus coincides with the guitar's return to the formation of clear phrases.

Similar to the use of the descending figure in Mary's dialogue, the descending line returns once again as a harbinger of musical material to follow throughout Christ's supplication to God. A descending <10> fragment on the word "Vater" (father) is followed by a <210> descent at the phrase "laß dir die" (let thou the), each contour pitch of the triplet figure equally accented at a *f* dynamic level (m. 10). The recurrence of the word "Wunden" (wounds) is appropriately cast in a <0132> contour whose initial three-pitch ascent, a replica of the contour sounding at the first occurrence of the word, is tempered by its final descending pitch (m. 11). The conclusive descent of the final contour pitch occurs appropriately when Christ asks God that his wounds serve as a sacrifice for all sin, the ultimate purpose for his pain being dramatically resolved. This vocal contour is reinforced by the guitar's overlapping repetition with the contour

in its inverted <3201> form as an accented melodic line (m. 11, bt. 2). The dramatic intensity of the ascending <012> figure is portrayed again at the words “ein Opfer” (a sacrifice), its reference to Christ’s ultimate sacrifice for the sins of the world being explained in the subsequent concluding poetic line (mm. 11-13). The final large ascent of the clarinet’s prime <102> contour by the registrally-removed contour pitches sounds beneath the words “ein Opfer” (mm. 11-12) (fig. 4.24).

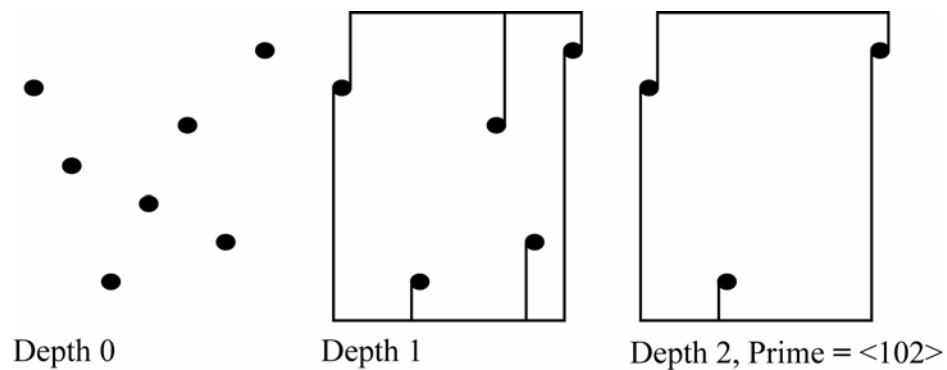

Fig. 4.24. Clarinet Contour <102>, mm. 11-12

The ascent of both contours anticipates Christ’s explanation that the extent of his sacrifice encompasses all the sins of man.

God’s address to Christ at the phrase “Sohn, lieber Sohn mein” (Son, my beloved son) is set in a fragmentary melodic line characterized by frequent occurrences of rests (mm. 14-15). Vocal subcontour <201> sounding on the accented syllables of the phrase “lieber Sohn mein” anticipates a full realization of this contour by the clarinet and guitar when God grants Christ his wish. Formation of the subcontour as a pointillistic melody interrupted by two eighth-note rests increases the sense of anticipation for God’s response to Christ’s request. The word of God is also foreshadowed by the guitar’s ascending figure, a <231405> contour whose gradual registral expansion creates a sense of expectation for musical resolution to come (m. 15). The last vocal contour <120>, a retrograde of <021> whose concluding descent is accented by its formation on two non-adjacent registral pitches, sounds decisively when God declares “das soll sein” (it shall come to pass) (mm. 17-18). The arrival of the final contour pitch is further emphasized by its *f*

dynamic level following an accelerating *crescendo*. The clarinet anticipates the concluding vocal contour beneath the word “alles” (all) before sounding three consecutive statements of <201> (mm. 16-18). The last clarinet contour emerges as an unaccompanied figure whose ending pitch is executed at a *sff* dynamic level. The final ascent of this clarinet contour leaves the listener in a state of heightened tension following the proclamation of God. The guitar mirrors the contours of the clarinet as two-note figures (m. 16) before sounding a concluding fragmentary statement of <201> (mm. 17-18) (fig. 4.25).

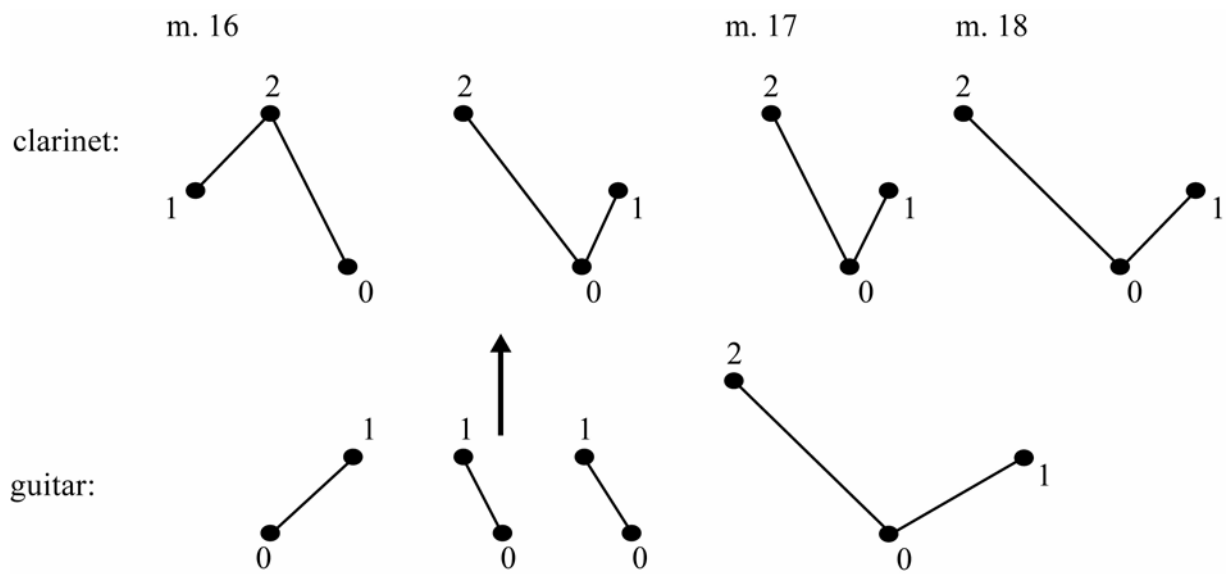

Fig. 4.25. Clarinet and Guitar Contours, mm. 16-18

CHAPTER FIVE

OP. 18, NO. 3 (“AVE REGINA COELORUM”):

A DEVOTION TO THE VIRGIN MARY

The third poetic text of Op. 18, “Ave, Regina coelorum,” is a two-part homage to the Virgin Mary. As in the poetic texts of the first two songs, the invocation to Mary is expressed through simple, direct poetic language. The medieval Latin prayer is couched in an unadorned wording, making it readily accessible to the Latin reader. In the first stanza, Mary is extolled for her virtuous presence as queen of the heavens and presider over the angels. She is also glorified as being a metaphorical vessel through whom light filters into the world. The second stanza takes a narrative turn when the reciter of the prayer entreats Mary both to rejoice and to intercede, along with Christ, on behalf of mankind. Throughout “Ave, Regina coelorum,” the rhyme schema highlights the devotional message of the poetic text. The first two lines, which establish Mary’s elevated status, are set apart as a rhyming couplet. Although the remaining six lines all end with the letter “a,” they are divided into couplets by means of the consonant preceding each final vowel. The “-ta” syllable that concludes the third and fourth lines demarcates Mary’s symbolic presence as a source of light for the world. In the second stanza, the speaker’s call for the Virgin to rejoice is set apart by a “-sa” ending and subsequent entreaty for her intercession with a “-ra” ending (fig. 5.1).

“Ave Regina”

Ave, Regina coelorum,	A
ave, Domina Angelorum:	A
Salve radix, salve porta,	B
ex qua mundo lux est orta:	B

“Hail, Holy Queen”

Hail, Queen of the heavens,
Hail, Ruler of the angels:
Hail fountainhead, hail portal,
From which the light of the world emanates:

Fig. 5.1. “Ave, Regina Coelorum” Rhyme Schema and English Translation

Gaude, Virgo gloriosa,	C	Rejoice, glorious Virgin,
super omnes speciosa!	C	Fairest of all!
Vale, o valde decora,	D	Farewell, o farewell Thou adorned one,
et pro nobis Christum exora.	D	And intercede along with Christ for us. ⁷⁹

Fig. 5.1. “Ave, Regina Coelorum” Rhyme Schema and English Translation (continued)

As in the first two songs of Op. 18, the metrically accented syllables are realized as vocal pitches of equal length or greater durational length than those of the metrically unaccented syllables. The first poetic line is cast in an irregular rhyme schema that directs attention to the textual establishment of Mary’s celestial supremacy. The second line forms a trochaic metrical pattern achieved in part because of the elided syllable at the word “Domina” (Ruler) (line 2). In accordance with the longstanding musical tradition of Latin text setting, Webern did not retain the elision in his setting of the vocal line.⁸⁰ Instead, he set the three syllables as an eighth-note triplet figure, a musical setting that reflects the dactylic versification of the word apart from its poetic context (fig. 5.2).

The image displays musical notation for two lines of Latin text. Above the text, horizontal lines indicate accents: a bar over the first syllable and a hook under the others. The first line is "A - ve, Re - gi - na coe - lo - rum,". The second line is "a - ve, Do - mi - na An - ge - lo - rum:". Below the text, musical notation shows eighth notes for unaccented syllables and eighth-note triplets for accented syllables. Brackets with the number '3' are placed under the triplets.

Fig. 5.2. Duration Lengths of the Vocal Pitches, Lines 1-2

⁷⁹I am indebted to Helmut Strothjohann for assisting me with this translation of “Ave, Regina coelorum” and for outlining the poem’s metrical beats.

⁸⁰Webern studied Latin at the Gymnasium in Klagenfurt, Austria during which Classical versification undoubtedly formed a core component of the curriculum. While completing his doctoral musicological studies under Guido Alder (1855-1941) at the University of Vienna, the composer prepared an edition of the second volume of Heinrich Isaac’s *Choralis Constantinus*, a task that intensely exposed him to medieval Latin musical settings.

The subsequent four lines produce a trochaic metrical pattern whose predictable regularity reflects the reciter’s unflagging adoration of the Virgin Mary as an exalted figure. The longest durational vocal pitch to sound in “Ave, Regina coelorum” is articulated at the word “gaude” (rejoice) (line 5), a musical accentuation of the text’s celebratory mood (fig. 5.3).

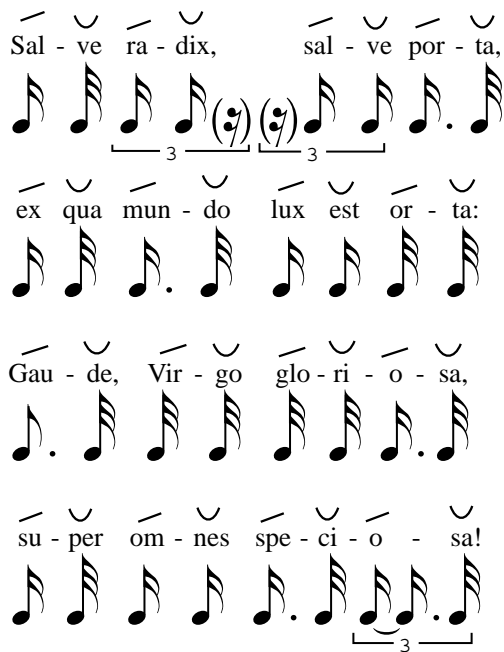

Fig. 5.3. Duration Lengths of the Vocal Pitches, Lines 3-6

The mood abruptly shifts in the final two lines as the reciter bids farewell to Mary and then recalls the sin of man. Owing to the elided syllables at the words “vale” (line 7) and “Christum” (line 8), as well as the spoken syllabic vowel inserted between the two syllables of the word “valde,” the metrical regularity continues throughout the remainder of the poem. As with the word “Domina,” Webern set each written syllable into the vocal line, thereby producing an effect of metrical irregularity that reflects the disharmonious nature of man’s sin. In two instances, the duration lengths of the vocal pitches contradict the poetic meter: at the exclamatory word “o” (line 7) and at the second syllable of the word “Christum” (line 8). An emphasis is thereby placed on the speaker’s final farewell address to the Virgin Mary and on

Christ's presence as an interceding figure (fig. 5.4).

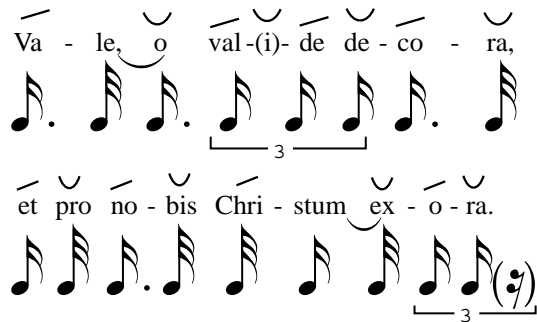

Fig. 5.4. Durational Lengths of the Vocal Pitches, Lines 7-8

Op. 18, no. 3 marks a clear turning point in Webern's dodecaphonic compositional approach. From this song on, he exclusively composed works built from linear row forms. T_4 row statements are presented in their entirety throughout the individual parts of the voice, clarinet, and guitar (fig. 5.5).

P4:	4	3	7	6	5	11	10	2	1	0	9	8
R4:	8	9	0	1	2	10	11	5	6	7	3	4
I4:	8	9	5	6	7	1	2	10	11	0	3	4
RI4:	4	3	0	11	10	2	1	7	6	5	9	8

Fig.5.5. T_4 Row Forms

Webern elided the beginnings and endings of several row forms in "Ave Regina," a compositional device he would exploit frequently throughout his latter twelve-tone works. The row pitches of the instrumental accompaniment often sound as rapidly-executed repeated notes, at times as a series of notes. This particular aural effect lends itself to a soothing predictability that evokes the message of adulation reiterated throughout the poetic text. Examination of the Op. 18, no. 3 row reveals an intervallic consistency yielding a large number of repeated and Z-

related sets, a further reminder of the text's unchanging tone (fig. 5.6).

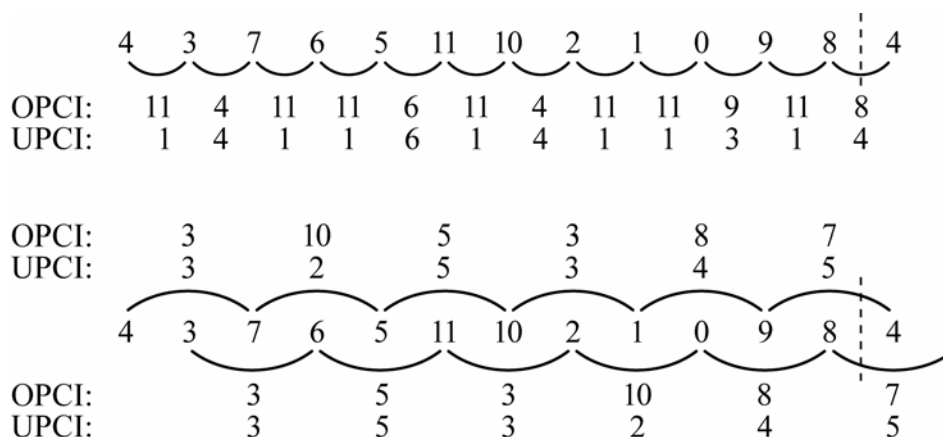

Fig. 5.6. Op. 18, no. 3 Row Intervals

Similar to the row of Op. 18, no. 2, IC 1 is heavily emphasized throughout the Op. 18, no. 3 row, an interval formed by pitch-class row adjacencies. Seven of the twelve row intervals are members of IC 1, each positioned within the row as OPCI 11. Because of the horizontal row layout, both the voice and clarinet lines are heavily saturated with IC 1 occurrences. These melodic IC 1s are built solely as larger intervals, many encompassing a UPI 11 span. The gentle OPI -1 descent featured in “Schatzerl klein” is thus abandoned in favor of dramatically expanded IC 1 forms that reflect the speaker’s profound adoration for the Virgin Mary. Harmonic UPI 11 statements formed from pitch-class row adjacencies are articulated pervasively throughout the guitar part. The direct intensity of the acerbic UPI 11 is often lessened by an intermediary pitch sounding between the two interval pitches. Frequently, however, UPI 11 emerges as an autonomous harmonic entity, its intervallic span echoing the identical sonority featured throughout the melodic lines. A gamut of larger IC 1 formations also sound throughout the vertical sonorities as the intervallic distance separating the individual voices from one another.

IC 4 occurs within the Op. 18, no. 3 row, albeit with less frequency than IC 1. In addition to the three IC 4s built from juxtaposing row members, neighboring row members separated by a single pitch class generate two more IC 4s. The interval recurs throughout the vocal line primarily as UPI 4, a modest intervallic leap that sounds in marked contrast to the larger IC 1

formations that surround them. Although compact versions of IC 4 emerge occasionally in the clarinet part, larger intervallic formations are presented more frequently throughout the clarinet's expansive melodic lines. IC 4 recurs throughout many of the trichordal guitar chords as UPI 8 or UPI 4, sonorities formed by pitches inserted between the harmonic UPI 11s. The outermost UPI 11 is built from adjacent row pitch classes with the intermediary pitch sounding as one of the two neighboring row members.

IC 5, the interval featured prominently throughout Op. 18, no. 1, occurs four out of twelve times as non-adjacent row intervals separated by a single row pitch class. The interval is notably absent within the melodic lines of the voice and clarinet, but is articulated frequently as UPI 5 throughout the guitar chords. Similar to the IC 4s in the guitar accompaniment, UPI 5 recurs often throughout the guitar chords as a neighboring row pitch positioned between a pair of adjacent UPI 11 row pitches. IC 5 also sounds frequently throughout the vertical sonorities, both as UPI 5 and as larger intervallic formations. Although the individual voices are most frequently separated from one another by a compact UPI 5 distance, this compressed intervallic span is periodically intermingled with larger compound formations.

The Op. 18, no. 3 row is made up of a limited number of sets, a compositional trait resembling the rows of the first and second Op. 18 songs. The repeated sets generated by the Op. 18, no. 3 row create a sound of soothing predictability, a phenomenon effected by Webern's strategic placement of intervals within the row. Six of the twelve trichordal sets belong to set 3-3, a sonority that is also featured prominently throughout the second song. The remaining trichordal sets are members of three discrete pairs: 3-5, 3-4, and 3-1. Repeated and related sets are also displayed prodigiously throughout the remaining row imbrications. Tetrachords 4-2, 4-3, 4-7, and 4-8 each occur twice throughout the row. Set pairs 4-2 /4-3, 4-3/4-7, and 4-7/4-8 have prime forms that differ from one another by a single semitone. Nine of the twelve pentachordal sets are repeated throughout the row: sets 5-1, 5-3, and 5-22 each occur twice and set 5-6 three times. With the exception of 5-22, a glimpse at the IC vector of the sets reveals that IC 1 occurs most frequently throughout each set. Repeated and Z-related sets figure ubiquitously throughout the hexachordal set imbrications. Sets 6-1 and 6-15 each occur two times in the row, the intense chromaticism of the former evoking the speaker's heightened expression of adoration. The remaining hexachordal sets are members of Z-related pairs: 6-Z36/6-Z3, 6-

Z37/6-Z4, and 6-Z44/6-Z19, the final pair sounding twice within the row. The extent to which Webern relied on the intervallic recurrences, as well as the row repetitions and related sets in highlighting the “Ave Regina” text, will be further examined throughout my discussion.

As in the first two songs, the intervals outlined in the instrumental introduction of “Ave, Regina coelorum” serve as predictors for latter intervallic unfoldings. Various IC 1 versions are stated in the clarinet melody, intervals that gradually increase in size throughout the introductory phrase. Four consecutive statements of OPI +11 are followed by two OPI -13 formations, then a concluding OPI -25 (mm. 1-4). This intervallic expansion reflects the dramatic tension that mounts throughout the poetic text: the reciter’s heightened expression of adoration for the Virgin Mary and his or her conscious realization of man’s worldly imperfections. A contrasting blend of smaller and larger intervals is presented throughout the guitar part. As with the clarinet melodies, both UPIs 11 and 13 occur prior to OPI -25 (mm. 1-2), an interval that sounds twice in measure three (m. 3, bt. 1; m. 3, bt. 3). Interspersed among the enlarged IC 1 formations are smaller intervals, most notably the OPI -3 that follows OPI -13 in the three-pitch melodic opening (m. 1). The guitar concludes the instrumental introduction with compact intervallic formations, trichords [4][11] and a harmonic [5][6], the outer UPI 11 of the second trichord reflecting the pitch interval that will come to predominate the guitar part (m. 4, bts. 1-2).

Various intervallic versions of IC 1 recur throughout the vocal part as reinforcements to the poetic text. The vocal line opens with a series of expanded IC 1 statements at the phrase “Ave, Regina coelorum” (Hail, Queen of the heavens) (mm. 4-6). A pair of OPI -11s is followed by two ascending intervals: OPI +13 and OPI +25, the latter of which coincides with the second accented syllable of the word “coelorum.” The upward sweep of this interval represents the largest intervallic leap to sound throughout the “Ave, Regina coelorum” vocal part. The second poetic phrase commences with an ascending OPI +13, an augmentation of the initial OPI -11 formation (m. 6, bt. 3). The enlarged intervallic opening anticipates the significant word “Domina” (Ruler) that establishes Mary’s divine supremacy. Following the [8][11] vocal descent of this word, the first two syllables of the word “angelorum” (of the angels) form OPI +4 (m. 7). This compact interval sounds in marked contrast to the previous enlarged vocal intervals, a musical denouement that coincides with the establishment of Mary’s celestial supremacy at the end of the first couplet.

The opening phrase of the second couplet, “salve radix” (hail fountainhead) begins with two expanded vocal intervals: OPI +23 and OPI -20 respectively. This melody features the largest vocal intervals to commence a poetic couplet in “Ave, Regina coelorum” (m. 9, bts. 1-2). Emphasis is thereby accorded to the maternal image of the Virgin Mary as a divine source for mankind. The intervallic composition of the second poetic couplet consists primarily of UPIs 11 and 13 (mm. 9-11). This uniform sound quality suggests the even glow of light cast from the halo encircling the Virgin Mary’s being. Similar to the first couplet, the second couplet concludes with OPI -4, an interval centered between two OPIs -11 and +13 at the phrase “lux est orta” (light emanates) (m. 11). This interval is the smallest to sound throughout the second poetic couplet (fig. 5.7).

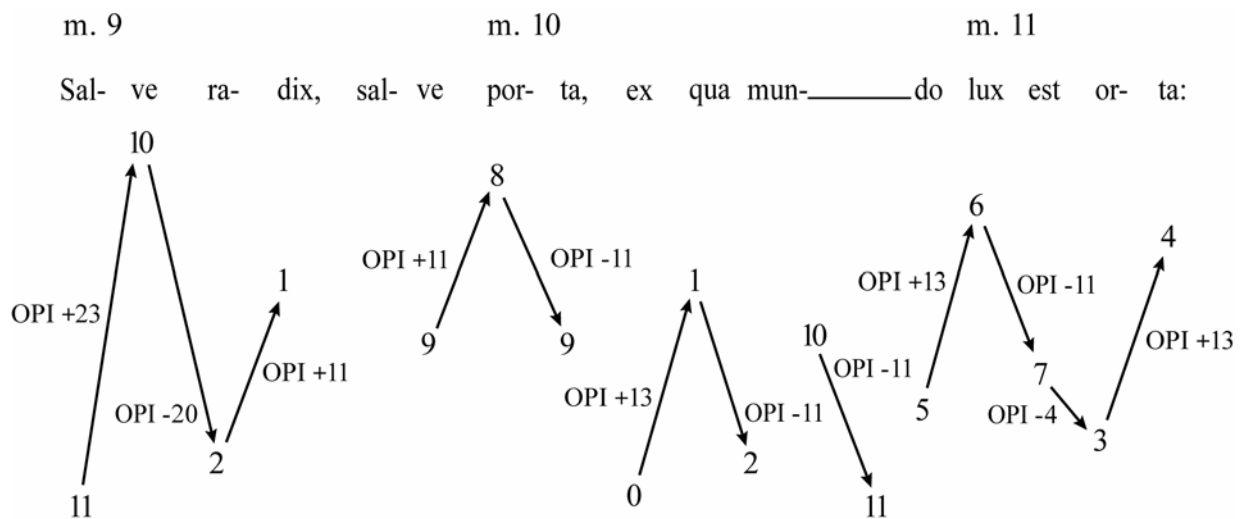

Fig. 5.7. Vocal Intervals, mm. 9-11

The intervallic composition of the instrumental accompaniment reflects the vocal intervals outlined in the first poetic stanza. As in the first two songs, harmonic guitar UPI 11s sound exclusively throughout the first stanza. Following an initial statement of UPI 11, the guitar leaps to the subsequent pitch forms OPI +23, an indicator of the subsequent vocal leap that will mark the word “Salve” (hail) at the opening of the second poetic couplet (m. 4, bt. 3). An ascending OPI +25 sounds at the beginning of a brief three-note guitar melody, a harbinger of

the subsequent vocal interval. (m. 5, bt. 3). Four UPI 11s accompany the opening vocal line, harmonic intervals devoid of an intermediary pitch. It is not until the utterance of the words “Domina Angelorum” (Ruler of the angels) that harmonic trichords appear in the guitar part as a reinforcement of Mary’s celestial supremacy (m. 7). A series of expanding clarinet intervals unfold at the identical phrase, a climactic expansion that underscores Mary’s hierarchical supremacy: OPI -13 is followed by OPIs -25 and -26 respectively. OPI -25 concludes the opening poetic couplet, a small contraction of the previous interval (m. 7, bt. 2-m. 8, bt. 2). As in the vocal part, the guitar articulates a dense series of UPI 11s at the second stanza, with a single exceptional trichordal harmony sounding before the metaphorical word “porta” (vessel) (m. 9, bt. 3). The clarinet dramatically marks the beginning of the second poetic couplet with a large OPI -35, the largest intervallic leap to sound in the clarinet line (m. 8, bt. 3-m. 9, bt. 1). With the exception of the OPI -25 accompanying the word “lux,” (light), UPIs 11 and 13 are the only UPCI 1 members to be sounded by the clarinet throughout the second couplet (m. 9-m. 11) (fig. 5.8).

The vocal range extends upward in the second stanza at the height of the reciter’s adulation for the Virgin Mary and his or her subsequent consciousness of man’s shortcomings. The phrase “Gaude, Virgo gloriosa” (Rejoice, glorious Virgin) begins on C6, the highest vocal pitch to sound up to this point in “Ave, Regina coelorum” (m. 12, bts. 1-2). The durational length of this pitch, which sustains for one-and-a-half eighth notes, is the longest to sound throughout the vocal part. This note value was heard only once before from a less conspicuous position on the third syllable of the word “Angelorum” (of the angels) (m. 8, bt. 1). The final poetic couplet commences with D6 on the word “Vale” (farewell), the registral apogee of the vocal line. This pitch extends well beyond the soprano tessitura, its jarring execution at a *f* dynamic level reflecting the dilemma of man as he yearns for the divine goodness of the Virgin Mary, which he cannot hope to attain (m. 16, bt. 1). C6 sounds again, both at the reciter’s exclamatory “o” as he or she consciously reflects on the sharp division between mankind and divinity, and at the word “Christum” (Christ) (m. 16, bt. 2; m. 18, bt. 2).

Both the penultimate and final stanzas consist solely of UPIs 11 and 13 interwoven among UPIs 3, 4, 6, and 8, with the notable exception of the OPI -15 descent that extends from the word “Christum” to the final word “exora” (intercede) (m. 18, bts. 2-3). The resultant

Sal- ve ra- dix, sal-ve por- ta ex qua mun- do lux est or- ta:

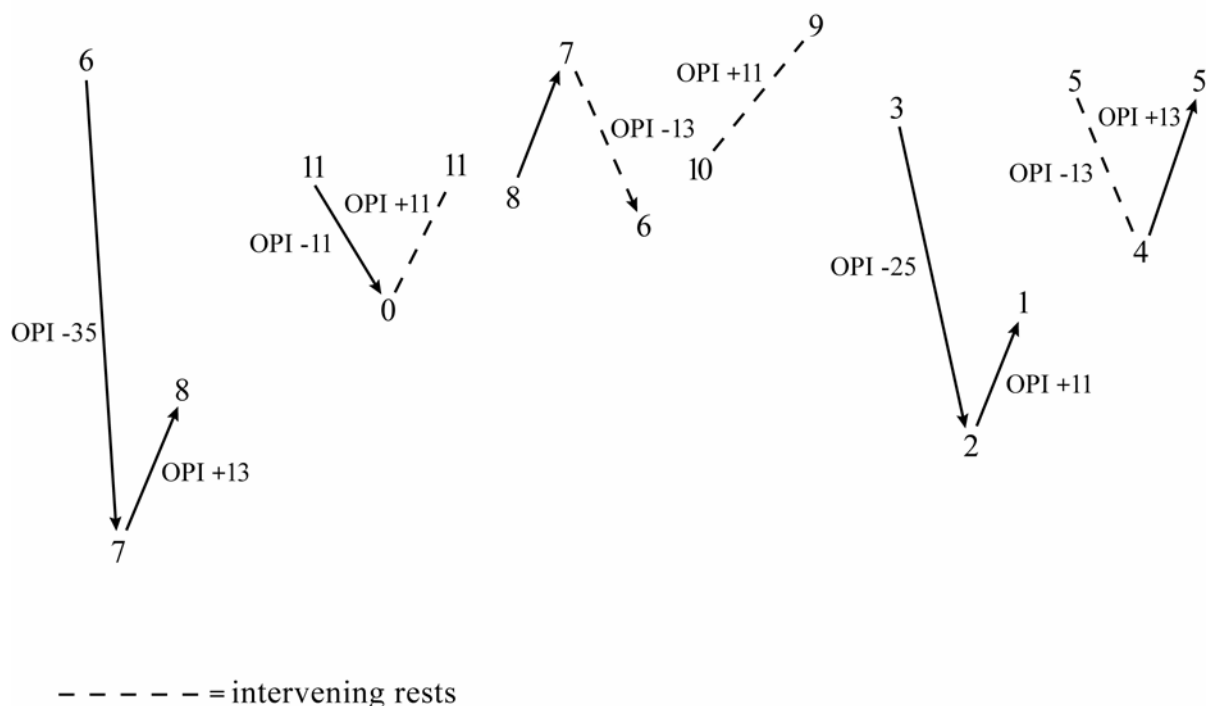

Fig. 5.8. Clarinet UPCI 1s, m. 8, bt. 3-m. 11

intervallic mosaic suggests the decorative Mary figure praised by the reciter throughout the second stanza. The melismatic setting of the words “speciosa” (fairest) and “nobis” (us) in the second lines of both stanzas places the image of Mary’s divine beauty against that of mankind (m. 14, bt. 2-m. 15; m. 18, bt. 1). This comforting vision of the maternal Mary figure consoling mankind closes the second stanza.

The intervals stated throughout the clarinet and guitar parts support the poetic text of the second stanza, in which the reciter’s mood shifts drastically between the first to the second poetic couplets. The guitar part consists of a dense UPI 11 progression that affirms the numerous vocal UPIs 11 and 13. A large OPI +33 extends upwards, its arrival on A5 marking the largest interval found in the guitar part of “Ave, Regina coelorum” (m. 12, bts. 2-3). The *f* execution of the second intervallic pitch echoes the dynamic level of the previous clarinet pitch, the first time the dynamic exceeds *mp*, at the joyful words “Gaude, Virgo” (Rejoice, Virgin). The guitar sounds a

large descending OPI -23 beneath the word “Vale,” its arrival anticipated by two *sf* trichords sounding in the momentary instrumental interlude between the first and second poetic couplets (m. 15, bt. 2-m. 16, bt. 1). In addition to sounding numerous UPIs 11 and 13, as well as a series of smaller intervallic formations, the clarinet forms large intervals that underscore the textual lines. OPI +25 marks the word “Gaude” (rejoice), the celebratory word initiating the second poetic stanza (m. 12, bt. 1). A series of three OPI -23s and an OPI +25 sound as an intervallic flourish that marks the close of the penultimate couplet at the word “speciosa” (fairest of all) (m. 15) (m. 15) (fig. 5.9).

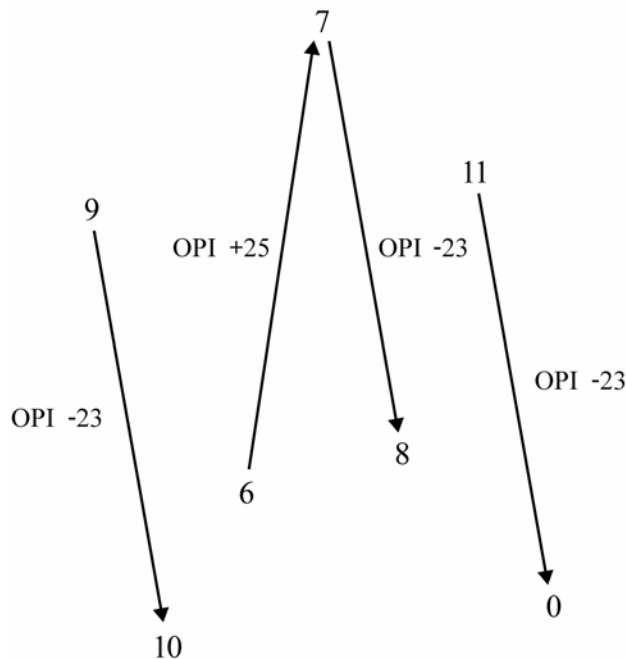

Fig. 5.9. Clarinet Intervals, m. 15

OPI -23 accompanies the word “Vale” (farewell), the initial sorrowful word of the final poetic couplet arrived at by a large OPI +32 leap (m. 15, bt. 2-m. 16, bt. 1). The repeated word “valde” (farewell) is also highlighted by a large interval, a descending OPI -28 that overlaps with the subsequent word “decora” (m. 16, bt. 3). The second descending interval sounding beneath the words “et pro” (and for) at the beginning of the closing poetic line forms OPI -25, a large interval that demarcates the reciter’s final plea to Mary (m. 17, bt. 3).

The instrumental postlude evokes the anguish experienced by the reciter as he or she prays fervently to the Virgin Mary, but cannot realize her divine goodness. The guitar initiates the postlude with a series of four trichords, the largest number of consecutive guitar trichords to sound in the song, followed by a contrasting pointillistic three-pitch melody (m. 19). This incongruous juxtaposition of the two figures evokes the reciter's perpetual dilemma as he or she adulates Mary, but remains trapped by the sins of Eve. B \flat 6 is articulated once more by the clarinet, this at a *ff* dynamic level, the loudest to sound in "Ave, Regina coelorum" (m. 19, bt. 2). The final descending clarinet melody begins with a B6, the highest registral pitch of the song that also sounds at a *ff* dynamic level (m. 20, bt. 3-m. 21, bt. 1). Both pitches are arrived at by OPIs +23 and +25 respectively, an expansion of the OPI +11 ascent that marks the previous arrival on B \flat 6 in the second stanza. The final clarinet figure concludes on a soft E5, a considerably lower register than the preceding B6 (m. 21, bt. 2). The extreme registral heights of these clarinet pitches evoke man's imperfect attempts to communicate with Mary, a strained sound further enhanced by the loud dynamic level. The final registral clarinet descent suggests the conclusion of the prayer as the reciter returns to his or her worldly concerns (m. 20, bt. 3-m. 21, bt. 1).

The limited number of sets highlighted in the instrumental introduction foreshadows the aural unity that will characterize "Ave, Regina coelorum." As in the beginning of "Erlösung," a series of densely chromatic sets are featured at the beginning of the song. The initial clarinet melody outlines 5-1, a pentachordal set echoed by the guitar towards the end of the instrumental introduction (m.1-m. 2, bt 1; m. 3, bt. 3-m. 4, bt. 1). The first guitar set, a softly executed 3-3 (m. 1), is repeated as the first two sets of the subsequent six-pitch melody, both sets accentuated by their steep upward ascent (m. 2-m. 3, bt. 1). In a similar fashion, set 3-3 is prominently positioned throughout the clarinet melodies: as a series of three consecutive trichords in the opening melody and the first set of the following clarinet melody (m. 1-m. 2, bt. 1; m. 2, bt. 3-m. 3, bt. 2). The clarinet and guitar melodies blend to form hexachord 6-Z3, its 6-Z36 Z-correspondent sounding as the concluding guitar phrase at the end of the instrumental introduction (m. 2-m. 3, bt. 2; m. 4, bts. 2-3). In addition to repeated sets, Z-correspondents and complementary sets will play a large part in creating additional aural signposts.

Hexachordal Z-correspondents 6-Z44 and 6-Z19 are positioned prominently throughout the vocal lines, thereby drawing associations between textual phrases. Set 6-Z44 sounds at the

words “Regina coelorum” (Queen of the heavens) when the reciter first addresses the Virgin Mary (mm. 5-6). The set resurfaces at the first line of the concluding couplet “o valde decora” (o farewell thou adorned one) as he or she bids Mary farewell (mm. 16-17). The recurring set thus frames the opening and closing of the “Ave, Regina coelorum” text. Accompanying the “o” exclamation, the clarinet articulates Z-correspondent 6-Z19, a melody distinctively sounding as two paired triplet figures (m. 16, bt. 2). Hexachord 6-Z44 marks the word “vale” (farewell) as a set formed by the instrumental accompaniment (m. 16, bt. 1). Its 6-Z19 complement sounds by the voice and guitar on the first two syllables of the word “decora” (m. 16, bt. 3-m. 17, bt. 1). Hexachords 6-Z19 and 6-Z44 are also built on the second and third melodic pitches of the phrase “ex qua mundo lux est orta” (from which the light of the world emanates) as the incandescent image of the Virgin Mary vividly emerges (mm. 10-11). The final guitar subset accompanying this phrase forms 6-Z44, a further reinforcement of the prominent hexachord (m. 10, bt. 3-m. 11, bt. 1). Hexachord 6-Z19 sounds from the initial pitch of the final vocal nonachord. The set encompasses the words “et pro nobis” (and for us), which are uttered as the reciter makes a plea for the Virgin Mary’s divine intercession (mm. 17-18). Her luminous image is thus recalled at the reciter’s lamentation on the sins of humanity, a soothing image of healing that presides over man’s suffering.

Z-related hexachordal sets 6-Z3/6-Z36 and 6-Z4/6-Z37 are positioned in proximity to one another throughout the three parts, creating a unified sound that transcends the surface difficulty of “Ave, Regina coelorum.” Set 6-Z36 is articulated at the vocal phrase “ex qua mundo” (from the world) (m. 10, bts. 2-3). Its Z-correspondent is formed by all three voices at the preceding word “porta” (vessel) (m. 10, bt. 1). The vocal phrase “Virgo gloriosa” (glorious Virgin) also sounds hexachord 6-Z36, thereby positing the glorious image of Mary against that of mankind (mm. 12-13). In a similar fashion, the vocal set is prefigured by the 6-Z36 set that marks the opening of the second poetic stanza: a hexachord built from all three parts and by the blending of the clarinet and guitar sonorities (m.12, bt. 1). Complementary hexachord 6-Z3 sounds simultaneously by the voice and clarinet at the beginning of the second stanza as a further enhancement to the word “Gaude” (Rejoice) (m. 12, bts. 1-2). Vocal subset 6-Z36 is articulated at climactic phrase “pro nobis Christum” (mm. 17-18). The image of Christ is thereby conjoined with that of the luminous Mary figure and mankind, a comforting vision that closes the prayer.

The concluding line of the first stanza is further connected to the subsequent poetic line by the hexachordal Z-correspondent pair 6-Z4/6-Z37. Set 6-Z37 sounds as the final vocal hexachord at the words “mundo lux est orta” (the light of the world emanates) (m. 10, bt. 3-m. 11). The voice and clarinet form hexachord 6-Z4, a further enhancement to the vocal set (m. 11, bt. 1). The phrase “Gaude, Virgo gloriosa “ (Rejoice, glorious Virgin) opens with hexachordal subset 6-Z4. Complementary set 6-Z37 marks the beginning of the expansive clarinet melody that extends to the second stanzaic line (m. 11, bt. 3-m. 12, bt. 2). The 432321 IC vector of the 6-Z4/6-Z37 Z-correspondents closely resembles that of 6-Z3/6-Z36: a 433221 IC vector differentiated by two ICs. Both poetic lines are thus characterized by the influx of similar-sounding hexachords that link the image of man with that of the Virgin Mary, a beacon of hope in answer to the reciter’s fervent prayer.

Complementary sets recur conspicuously throughout the vocal lines, creating additional associations between the textual phrases. The vocal line sounds set 3-3 at the words “salve porta” (hail, vessel), a phrase demarcated by the rests surrounding it (mm. 9-10). The trichord is further reinforced by the brief melodic clarinet figure accompanying the word “porta” (m. 10, bts. 1-2). In addition, a large complementary 9-3 guitar set extends from the conclusion of the first stanza throughout the words “Salve radix” (hail fountainhead), the initial phrase of the second poetic couplet (m. 8, bt. 2-m. 9, bt. 2). This oft-recurring row set is thus associated with Mary’s translucent being, a divine vessel through which light enters into the world.

Complementary set 9-3 encompasses the subsequent vocal phrases “super omnes speciosa” (fairest of all) and “et pro nobis Christum exora” (and intercede along with Christ for us) (mm. 13-15, mm. 17-18). Guitar nonachord 9-3 accompanies the word “speciosa” (fairest), a distinctive phrase set off from the previous guitar material by an intervening rest (m. 14, bt. 2-m. 15). A harmonic 3-3 guitar set marks the end of the final poetic phrase, a parallel closing gesture (m. 18, bt. 3). The translucent image of Mary is recalled, both when she is depicted as the most beautiful woman and at the reciter’s entreaty for divine intervention on behalf of mankind.

In addition to the 3-3/9-3 pair, complementary sets 4-3 and 8-3 sound at a pivotal moment in the “Ave, Regina coelorum” poetic text. Tetrachord 4-3 is articulated at the words “Salve radix” (Hail fountainhead), its 8-3 complement subsequently formed on the phrase “Gaude, Virgo gloriosa” (Rejoice, glorious Virgin) (m. 9, bts. 1-2; m. 12-m. 13, bt. 1). Guitar

tetrachord 4-3 accompanies the word “Gaude” (rejoice), a further reinforcement of the vocal octachord (m. 12, bts. 1-2) (fig. 5.10).

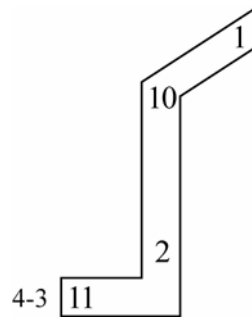

Fig. 5.10. Guitar Tetrachord 4-3

The comforting image of Mary’s being serving as a divine source for humanity is recalled at the reciter’s praising of her glorious beauty. Her celestial beauty is thus linked to the metaphorical reference of her physical being as a maternal source for humanity.

Chromatic complementary sets are highlighted throughout “Ave, Regina coelorum,” an intense sound accompanying the fervent prayer to the Virgin Mary. The 3-1 set formed on the word “Regina” (queen) is complemented by the 9-1 chromatic set that spans the phrase “Regina coelorum” (Queen of the heavens), a nonachord created by the fusing of all three parts (m. 5, bt. 2-m. 6, bt. 1). The set is built by the vocal “Domina” (Ruler) along with the two accompanying clarinet melodies, thereby emphasizing Mary’s divine hierarchical supremacy (m. 7). The word “speciosa” (fairest of all) sounds nonachord 9-1, a set formed by all three parts on the first two syllables of the word (m. 14, bt. 2). The final two syllables of the word “speciosa” are accompanied by clarinet septachord 7-1, a set that marks the conclusion of the penultimate stanza. In turn, clarinet pentachord 5-1 sounds at the words “Christum exora” (intercede with Christ) (m. 18, bts. 2-3). The beautified image of Mary is thus linked to Christ as the reciter prays for divine intercession.

Several sets are reiterated throughout the instrumental postlude, a reminder of man’s inability to overcome his earthly afflictions. Guitar set 3-3 frames the beginning and end of the postlude as an untransposed, repeated set (m. 19, bt. 1; m. 21, bt. 3). The beginning trichord is

the first of four consecutive trichords, three of which are 3-3 members (m. 19, bts. 1-2). Complementary set 9-3 is formed twice on the first and second chords of the trichordal series, followed by a sparse melodic 3-3 guitar set (m. 19). The clarinet articulates a melodic 3-3 trichord, after which a subsequent 9-3 complementary set is played by the clarinet and guitar (m. 19, bts. 1-2; m. 20, bt. 3-m. 21). A distinctive harmonic 3-3 guitar trichord sounds within the nonachord, a set accentuated by its *fff* dynamic level (m. 20, bt. 3). The clarinet articulates septachord 7-1 in the postlude as a dramatic figure in which the arrival on the second pitch represents the loudest dynamic level to sound up to this point in “Ave, Regina coelorum” (m. 19, bt. 2-m. 20, bt. 1). The final clarinet melody spells out an 8-7 octachord, the closing melody executed at a *ff* dynamic level, which drops sharply to a *p* dynamic level (m. 20, bt. 2-m. 21). The vocal line anticipates this octachord, combining with both the accompanying clarinet melody and the guitar material at the closing phrase “Christum exora” in forming two 8-7 octachords, a set also created by all three parts (m. 18, bts. 2-3).

The contours sounding throughout “Ave, Regina coelorum” also highlight the speaker’s intense expression of adoration for the Virgin Mary. Prime contour <1032> shapes the opening vocal line of the first stanza, “Ave, Regina coelorum” (Hail, Queen of the heavens), a sonority that is also echoed at the stanza’s closing line “ex qua mundo lux est orta” (from which the light of the world emanates) (m. 4-m. 6, bt. 1; m. 10, bt. 2-m. 11) (fig. 5.11). The opening image of the Virgin Mary as queen of the heavens is thus recalled when she metaphorically sheds light onto the world. Contour <1032> is built from two descending intervals, the second of which is positioned in a higher register above the first. The registral ascent of the second interval belies the sense of resolution that would normally accompany a final melodic descent. This lack of clear-cut musical resolution suggests the reciter’s inability to overcome his or her burden of original sin, even while praying fervently to the Virgin Mary.

A sense of heightened suspense is also suggested by the vocal contours appearing at the end of the first and the beginning of the second poetic couplets (fig. 5.12). The words “ave, Domina” (hail, Ruler) that constitute the first half of the second line are melodically shaped as a <13420> contour (m. 6, bt. 3-m. 7, bt. 2). Subcontour <420> sounds decisively at the word “Domina” (Ruler), its conclusive descent from the highest to lowest contour pitches serving as

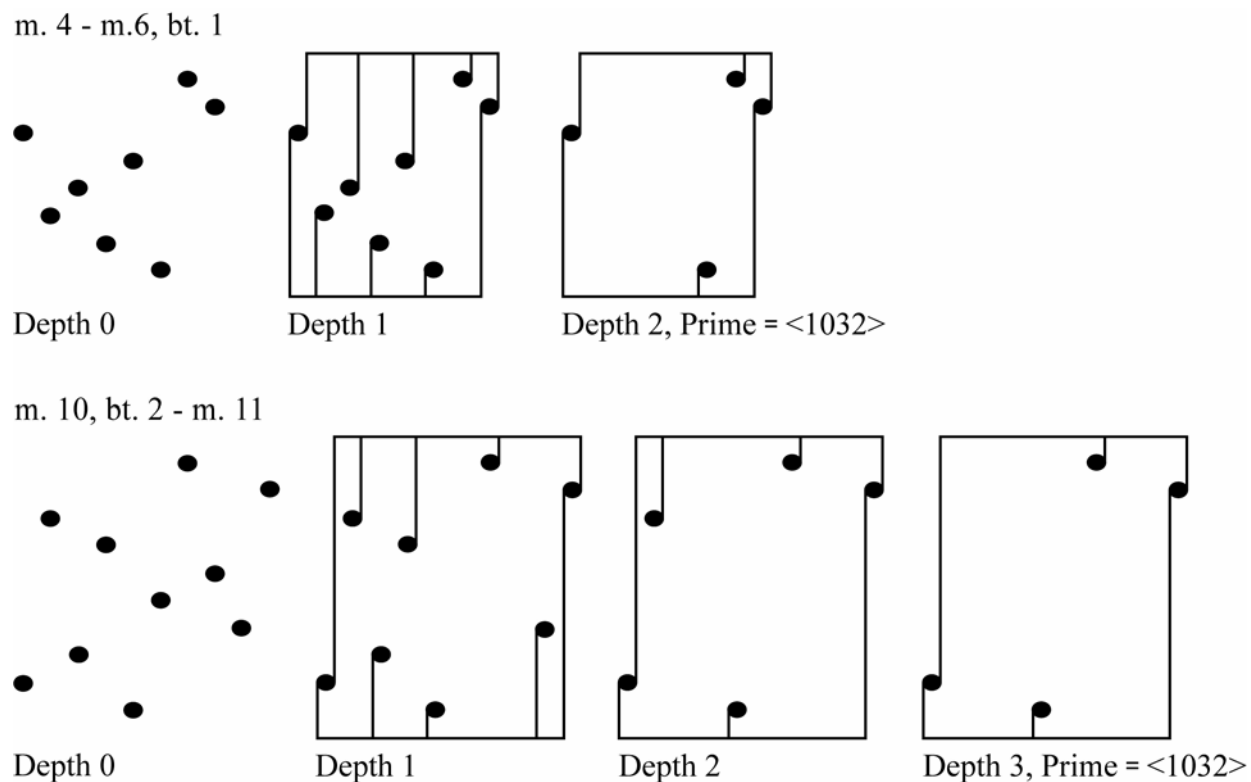

Fig. 5.11. Vocal Contour <1032>

an aural affirmation of the Virgin Mary’s celestial supremacy. Immediately following this phrase, however, the word “Angelorum” (of the angels) is cast as a contrasting <1302> contour (m. 7, bt. 3-m. 8). Its final ascent anticipates musical material to come following the conclusion of the first stanza. In a similar manner, two disparate contours shape the beginning of the fourth poetic line. The initial phrase “Salve radix” (Hail fountainhead) forms a <0312> contour built from a pair of ascending lines (m. 9, bts. 1-2). The first half of the subsequent phrase echoes the ascending line at the word “salve” (hail) followed by the contrasting descent of the word “porta” (vessel) (m. 9, bt. 3-m. 10, bt. 1). This musical descension concludes the first half of the fourth line, in which the Virgin Mary is metaphorically represented as a divine vessel. The final above-mentioned <1032> contour that ends the second stanza stands in marked contrast to the previous contour. Its tension-laden sound emerges as the image of Mary’s divine being is jarringly juxtaposed against that of the imperfect world.

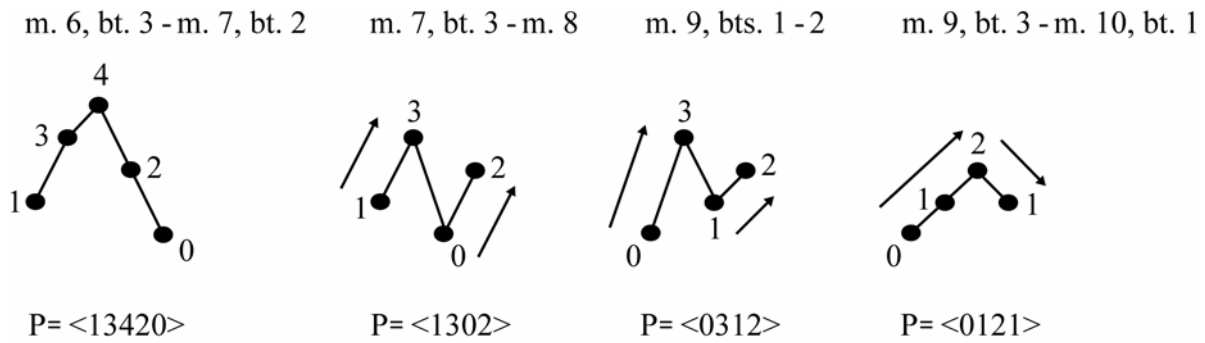

Fig. 5.12. Vocal Contours, Stanzas One and Two

The contours outlined in the instrumental introduction foreshadow the ascending intervallic pairs, as well as the sharp rise and fall of the <13420> “Ave, Domina” (hail, Ruler) contour (fig. 5.13). The clarinet commences with two consecutive rising figures, which in turn conclude the instrumental introduction, this time played by the guitar (m. 1-m. 2, bt. 1; m. 3, bt. 3-m. 4). Both the guitar and clarinet outline large, melodic figures that trace the ascent and descent of the <13420> contour. The guitar initiates a <023541> contour accentuated by its numerous repeated notes (m. 2-m. 3, bt. 1). A <10> guitar fragment follows the expansive contour as an aural reinforcement of the previous descending line (m. 3, bt. 3). In a similar fashion, the clarinet sounds contour <02431> along with the guitar contour, a larger contour that is also followed by a <10> contour (m. 2, bt. 2-m. 4).

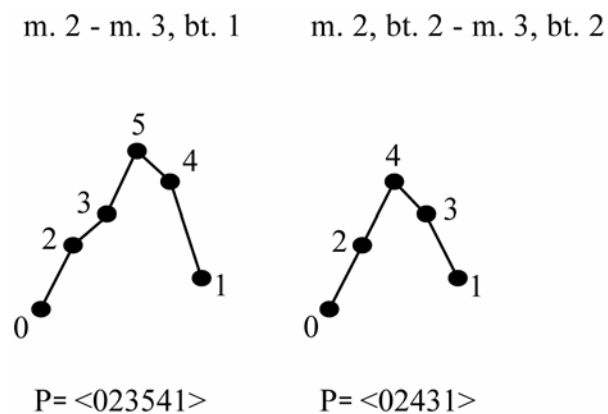

Fig. 5.13. Clarinet and Guitar Contours, Instrumental Introduction

Both the clarinet and guitar trace the vocal contours that shape the words “Ave, Domina” (hail, Ruler). The vocal <210> descent of the word “Domina” is subsequently echoed in the clarinet part by four descending subcontours (m. 7, bt. 2-m. 8, bt. 2). The ascending intervals of contour <1302> at the word “Angelorum” (of the angels) is in turn outlined by two rising guitar figures, the first of which precedes the vocal contour (m. 7, bt. 2-m. 8, bt. 1).

Contour <201> recurs throughout the vocal line in the second part of the song, emphasizing both the speaker’s idealized view of the Virgin Mary and his or her cognizance of worldly sin (fig. 5.14). Subcontour <201> emerges at the end of the first stanza, a contour formed on the salient registral points of the phrase “lux est orta” (light emanates) (m. 11). This contour stands in relief because of the duple meter and *tenuto* articulation that differentiates it from the previous measure. The subsequent poetic line, “Gaude, Virgo gloriosa” (Rejoice, glorious Virgin), also sounds <201> as the prime contour of an eight-note melody (m. 12-m. 13, bt. 1). A sparse <01> prime contour surfaces at the phrase “super omnes speciosa” (fairest of all), its upward sweep accentuated by the melismatic setting of the word “speciosa” (fairest) (m. 13, bt. 2-m. 15). All three poetic lines emphasize Mary’s divine beauty and the vivid image of light emanating from her being, followed by a depiction of her radiant loveliness.

Both concluding lines present a picture of the virtuous Mary figure in contrast to that of mankind. The final poetic couplet is set apart from the previous musical material by the unprecedented *f* dynamic level of the vocal line and the *ritardando* that marks the ending of the penultimate couplet. Contour <201> sounds pervasively throughout the second-to-last line, first at the words “Vale, o”, then as a pair of elided contours at the syllabic phrase “valde decora,” contours that join together in creating a prime form of the contour (Farewell, o farewell Thou adorned one) (m. 16-m. 17, bt. 1). The ending phrase “Christum exora” (intercede along with Christ) is also cast as a <201> contour (m. 18, bts. 2-3). Contour <201>, a figure that also imbues the ending of “Erlösung,” sounds throughout the second part of “Ave, Regina coelorum” as an emblem of the poem’s narrative conflict. The unresolved tension of its final ascent alludes to the reciter’s perpetual living agony as he or she worships the Virgin Mary, but cannot personally attain divine perfection.

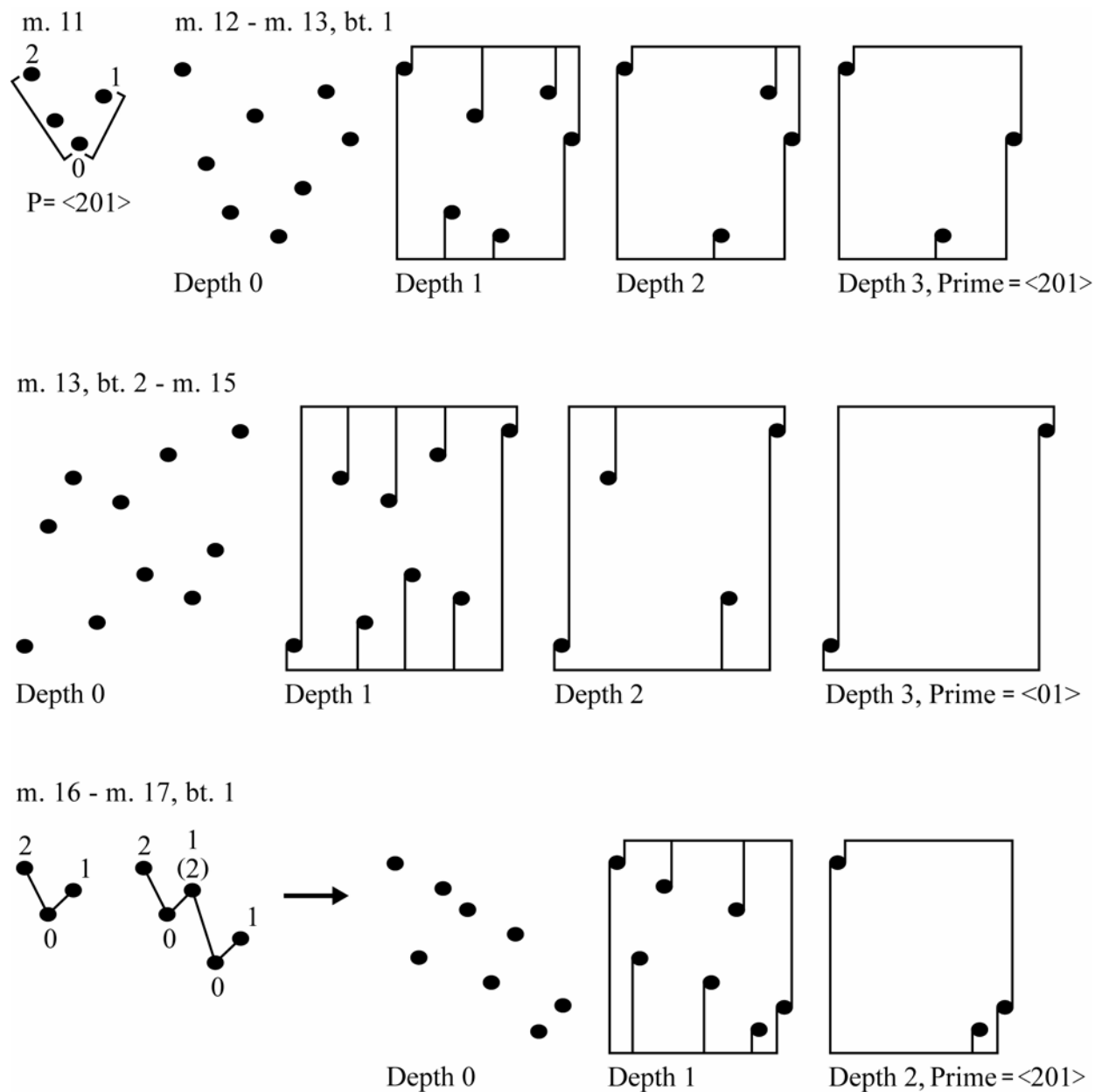

Fig. 5.14. Vocal Contour <201>

The clarinet and guitar both foreshadow the prominent vocal <201> contour that shapes the phrase “lux est orta” (light emanates) by articulating contour <102>, the retrograde of <201>, along with the vocal line and throughout the musical material preceding its arrival (fig. 5.15). The clarinet outlines the initial descent of the contour at the word “salve” (hail), which is succeeded by a complete <102> statement at the word “porta” (fountainhead) (m. 9, bt. 2-m. 10,

bt. 2). The ascent to the final contour pitch is then anticipated by the clarinet above the words “ex qua mundo” followed by a second <102> at the words “lux est” and a closing <01> ascent accompanying the word “orta” (from which the light of the world emanates) (m. 10, bt. 2-m. 11). The guitar produces a <102> contour whose initial contour pitch precedes the arrival of the subsequent two pitches on the phrase “lux est orta” (m. 10, bt. 3-m. 11, bt. 1). Its final contour pitch is articulated as a series of two harmonics, an aural effect not heard since the instrumental introduction. This ethereal sound effect appropriately accompanies the mystical image of the Virgin Mary surrounded by a halo.

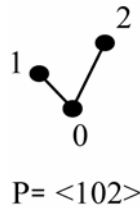

Fig. 5.15. Instrumental Contour <102>

Contour <201> also recurs throughout the instrumental accompaniment in the second part of the song as a further enhancement to the prominent vocal contours (fig. 5.16). This contour is first foreshadowed by the guitar, following the opening line “Ave, Regina coelorum” (Hail, Queen of the heavens), its final ascent repeated as a quieting, *staccato* figure (m. 6, bts. 2-3). The clarinet subsequently sounds <201> beneath the <210> contour that shapes the word “Domina” (Ruler) (m. 7, bt. 1). This contour overlay, the decided resolution of the vocal contour, accompanied by the unresolved clarinet contour, reflects the poem’s dramatic conflict: man’s intense adulation of the Virgin Mary and his inability to emulate her perfections. The clarinet articulates the first note of contour <201> in the momentary instrumental interlude following the first poetic couplet, its final two contour pitches coinciding with the words “salve radix” (hail fountainhead) (m. 8, bt. 3-m. 9, bt. 2). The image of Mary as a source of purity is thus accompanied by the aural motif that will come to represent man’s sin throughout the second stanza.

Contour <201> is played by the guitar along with the identical vocal contours at the

beginning and ending of the final two couplets, sometimes in conjunction with the clarinet. Guitar contour <01>, a <201> subcontour, accompanies the first syllable of the word “Gaude,” a prime contour whose initial contour pitch overlaps the final vocal “-ta” syllable of the first stanza (m. 11, bt. 2-m. 12, bt. 2). Then, the clarinet commences an expanded <201> contour over the final sustained pitch of the guitar subcontour. The *fpp* execution of its first pitch represents the first time the dynamics exceed a *mp* level, appropriately sounding above the word “Gaude” (Rejoice) as a trumpeting of Mary’s joyous presence. The clarinet contour extends throughout the phrase “Gaude, Virgo gloriosa” (Rejoice, glorious Virgin) along with the identical vocal contour (m. 12, bt. 2-m. 13, bt. 2). Contour <201> is subsequently stated by the guitar as a three-pitch figure sounding beneath the first two syllables of the word “speciosa” (fairest) and the word “vale” (m. 14, bt. 2; m. 16, bt. 1). Following suit, the clarinet articulates <201> on the second two syllables of the word “speciosa.” It emerges again as the prime contour of the rapidly executed notes that extend from the second syllable of the word “vale” to the exclamatory “o” (m. 16, bts. 1-2). The clarinet marks the ending of the penultimate line with a consecutive <201> contour (m. 16, bt. 3-m. 17, bt. 1). After the word “vale” is uttered, contour <201> is formed by the guitar on its salient registral points, accompanying the phrase “o valde de-” (m. 16, bts. 2-3). A three-pitch <201> guitar contour closes the second stanza at the word “exora” (m. 18, bt. 3).

Contour <201> is reiterated both by the clarinet and the guitar in the instrumental postlude. The guitar forcefully articulates this contour at the loudest dynamic level to sound throughout “Ave, Regina coelorum;” the *sff* dynamic level of its initial pitch is followed by two *ff* pitches (m. 19, bt. 2). In a similar manner, the clarinet initiates contour <201> at a *ff* dynamic level, both preceding the beginning of the guitar figure and at the end of the song (m. 19, bt. 2; m. 20, bt. 3). The clarinet’s concluding <201> contour sharply drops to a *p* level at its final contour pitch, which in turn sustains over the closing <01> of the guitar (m. 20, bt. 3-m. 21). The guitar’s final ascent sounds as a softly executed figure whose final unaccompanied pitch closes “Ave, Regina coelorum,” a whispered reminder of man’s inability to overcome his earthly foibles (m. 21, bts. 2-3).

m. 11, bt. 2 - m. 12, bt. 2

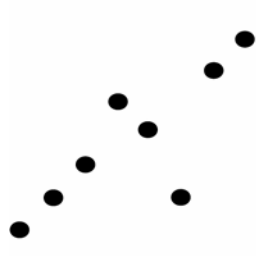

Depth 0

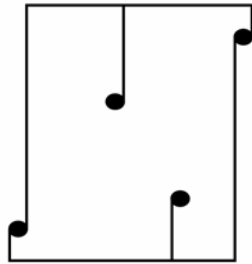

Depth 1

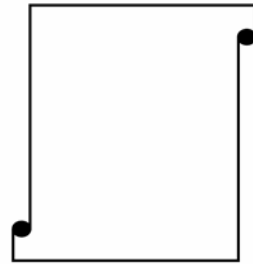

Depth 2, Prime = $\langle 01 \rangle$

m. 12, bt. 2 - m. 13, bt. 2

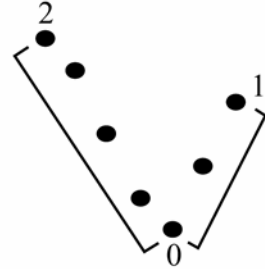

P = $\langle 201 \rangle$

m. 16, bts. 1 - 2

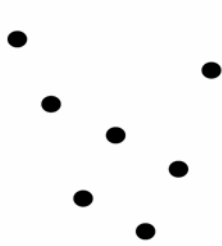

Depth 0

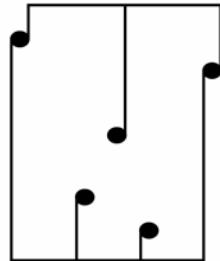

Depth 1

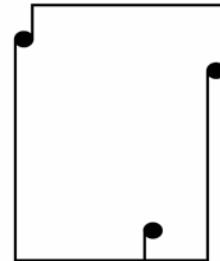

Depth 2, Prime = $\langle 01 \rangle$

m. 16, bts. 2 - 3

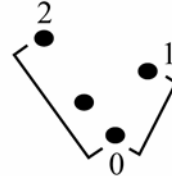

P = $\langle 201 \rangle$

Fig. 5.16. Instrumental Contour $\langle 201 \rangle$

CHAPTER SIX

CONCLUSION AND IMPLICATIONS FOR FURTHER STUDY

Webern's *Drei Lieder*, Op. 18 row settings have often been described by scholars as being chaotic in nature, an imperfect foreshadowing of the composer's "mature" twelve-tone works. My study has challenged this prevailing view by identifying a limited number of sonorities that resurface throughout the songs as a means of underscoring the poetic texts. Sets and intervals generated by the row, as well as those created by non-adjacent row members, often sound along with their related forms as a further textual reinforcement. The narrative events and moods of the poems are also evoked by adjacent and non-adjacent pitch contours. These repeating sonorities emerge among a diverse array of dynamics, rhythms, registral locations, and articulation markings that highlight their presence in the musical texture. As with Goethe's *Urpflanze* concept, that of an underlying sameness connecting diverse plant parts, the intricate texture of Op. 18 is characterized by perceptibly recurring sonorities. My study represents the first large-scale work to examine the text-texture relationship of Op. 18 by means of a combined analytical approach. Webern's other "transitional" twelve-tone vocal compositions, Opp. 17 and 19, both of which have been likewise neglected, would also benefit from this method.

Interspersed among the comments in the general Webern literature pertaining to the purported analytical inaccessibility of Op. 18 are statements regarding the potential difficulties in performing the work. Malcolm Hayes voices strong reservations about the possibility of achieving a clean performance of the songs:

...it is questionable whether an entirely commanding and accurate performance by any singer of the opus 18 settings is actually feasible. There is a strong sense in this work that Webern was pursuing a genre of musical transcendence that is simply beyond the capacity of a small line-up of vocal and instrumental forces.⁸¹

⁸¹Malcolm Hayes, *Anton von Webern* (London: Phaidon, 1995), 145.

Friedrich Wilgans comments briefly on the technical performance challenges posed by Op. 18, namely those of the large intervallic leaps in the second and third songs and the rhythmic intricacy of the third song.⁸² In a similar light, Walter Kolneder describes the vocal part as going “beyond the bounds of possibility”.⁸³ Wallace McKenzie points out what he perceives as erraticism of the unusually large vocal range. Noted Webern biographer Hans Moldenhauer limits his comments on Op. 18 to the “extreme difficulty” of the vocal part, as well as the rhythmic and contrapuntal complexity of the work’s musical texture.⁸⁴ Anne Shreffler describes Op. 18 as a work that “resist[s] performance and analysis.”⁸⁵ The premiere performance of this work took place on 8 February 1954, twenty-nine years after it had been written, under conductor Robert Craft. Op. 18 has been recorded a mere four times, each performance being included on an all-Webern recording.⁸⁶ The fact that this work has not been incorporated onto a recording with other composers’ works, particularly on those showcasing the clarinet, guitar, or voice, indicates that it has not been widely accepted beyond the community of specialized Webern performers.

In response to this dearth of recordings, it would be worth examining the analytical ramifications imbedded in the performance of Op. 18. As Webern’s seminal serial work, Op. 18 deserves to occupy a prominent niche in the early twentieth-century performance repertoire. My multifaceted analytical approach is preceded by a post-tonal primer that would provide performers with the information needed to decipher my analysis. Cognizance of recurring and related sonorities would help performers avoid note-by-note playing, instead providing them with a framework within which to portray the poetic texts. Elizabeth West Marvin and Robert W. Wason’s collaborative performance-analysis study of early Webern songs serves as a model

⁸²Friedrich Wildgans, *Anton Webern*, trans. Edith Temple Roberts and Humphrey Searle (New York: October House, 1967), 137.

⁸³Walter Kolneder, *Anton Webern: An Introduction to His Works*, trans. Humphrey Searle, 104.

⁸⁴ Hans Moldenhauer and Rosaleen Moldenhauer, *Anton von Webern: A Chronicle of His Life and Work*, 317.

⁸⁵Anne Shreffler, “‘Mein Weg geht jetzt vorüber’: The Vocal Origins of Webern’s Twelve-Tone Composition,” 278.

⁸⁶Anton Webern, *Anton Webern: The Complete Recordings*, Robert Craft, conductor, CK4L-232, 1957. Anton Webern, *6 Songs after Georg Trakl, Op. 14 (1917-21); 5 Sacred Songs, Op. 15 (1922-23); 5 Canons, Op. 16; Three Sacred Folk Songs, Op. 17 (1924); Three Songs, Op. 18 (1925)*, Amsterdam Ensemble, Robert de Leeuw, conductor, Tel. 642350, 1978. Anton Webern, *Anton Webern: Complete Works, Opp. 1-31*, Pierre Boulez, conductor. 45845, 1978. Anton Webern, *Complete Webern*, Pierre Boulez, conductor, 457 637-2, 2000.

for shaping such an investigation. Each song discussion commences with a brief analysis, in which Wason outlines the sonorities that highlight the form and meaning of the poetic texts. Both Wason and Marvin look to these analyses in selecting subtle tempo and dynamic variants, as well as inserting caesuras and selecting tone colors to clearly convey the musical phrases. In addition, Marvin points out related sonorities in the individual parts that serve to facilitate interactive ensemble playing. She also identifies recurring motifs that assist the singer in efficient practicing as well as creating non-contiguous aural associations that avoid the potential of a song being incorrectly sung if a single interval is missed.⁸⁷ Heinrich Schenker's annotated scores of the Beethoven piano sonatas also provide a useful paradigm for a performance-analysis approach. The renowned theorist included fingerings he believed would best communicate the structure and affect of a given Beethoven piano sonata.⁸⁸ The purpose of the above-outlined performance-analysis approach would be to facilitate in performance a clear communication of the aural structures that characterize *Drei Lieder*, Op. 18. Opp. 17 and 19, works likewise cited for their extreme difficulty, could also be made more accessible by a performance-analysis approach.

⁸⁷Elizabeth West Marvin and Robert W. Wason, "On Preparing Anton Webern's Early Songs for Performance: A Collaborator's Dialogue," 91-124.

⁸⁸William Rothstein, "Heinrich Schenker as an Interpreter of Beethoven's Piano Sonatas," *19th Century Music* 8, no. 1 (Summer 1984): 10.

SELECTED BIBLIOGRAPHY

Primary Sources: Letters and Writings

Schönberg, Arnold. *Style and Idea*. Edited by Leonard Stein. New York: St. Martin's Press, 1975.

_____. *Theory of Harmony*. Translated by Roy E. Carter. Berkeley: University of California Press, 1978.

Webern, Anton. *Briefe an Hildegard Jone und Josef Humplik*. Edited by Josef Polnauer. Translated by Leo Black. Vienna: Universal Edition, 1959.

_____. *Wege zur neuen Musik*. Edited by Willi Reich. Vienna: Universal Edition, 1960.

_____. *The Path to New Music*. Edited by Willi Reich. Bryn Mawr, Pa.: Theodore Presser, 1963.

_____. *Letters to Hildegard Jone and Josef Humplik*. Edited by Josef Polnauer. Translated by Cornelius Cardew. Bryn Mawr, Pa.: Theodore Presser, 1967.

Secondary Sources: Webern Studies

Bailey, Kathryn. *The Twelve-Note Music of Anton Webern*. Cambridge, England: Cambridge University Press, 1991.

_____. "Coming of Age." *The Musical Times* 136 (December 1995): 644-9.

Baldenius, Imke. "Stiluntersuchungen an den Opera 3, 4, 16, 17, 18 und 29 Anton Weberns." Master's thesis, University of Hamburg, 1959.*

Banks, Myra. "Serial Techniques and Formal Principals." Ph.D. diss., University of Glasgow, 1968.

Beckmann, Dorothea. *Sprache und Musik im Vokalwerk Anton Weberns: Die Konstruktion des Ausdrucks*. Regensburg: Bosse, 1970.

Broekema, Andrew J. "A Stylistic Analysis and Comparison of the Solo Vocal Works of Arnold Schoenberg, Alban Berg, and Anton Webern." Ph.D. diss., University of Texas at Austin, 1962.

- Cholopowa, Valentina, and Juri Cholopow. *Anton Webern: Leben und Werk*. Translated by Christoph Hellmundt. Berlin: Henschelverlag, 1989.
- Hathey, Thomas Harold. "The Central Period Oeuvre of Anton Webern, Opp. 12-19: A Study of Dynamic Infusion-Spacings in View of the Gestalt and Its Implications for Analysis." Ph.D. diss., Yale University, 1995.*
- Hayes, Malcolm. *Anton von Webern*. London: Phaidon, 1995.
- Hilmar, Ernst, ed. *Anton Webern 1883-1983*. Vienna: Universal Edition, 1983.
- Jeffers, Robert E. "An Analysis of Webern's Op. 18." D.M.A. thesis, University of Illinois, Urbana-Champaign, 1983.
- Johnson, Julian. *Webern and the Transformation of Nature*. Cambridge, England: Cambridge University Press, 1999.
- Kolneder, Walter. *Anton Webern: An Introduction to His Works*. Translated by Humphrey Searle. Westport, Conn.: Greenwood, 1968.
- Kronick, Melanie S. "Musical Invention and Poetry in the Late Vocal Works of Anton Webern." Ph.D. diss., The Louisiana State University and Agriculture and Mechanical College, 1992.
- Leibowitz, René. *Introduction à la musique de douze sons*. Paris: L'Arche, 1949.
- Lynn, Donna. "Genesis, Process, and Reception of Anton Webern's Twelve-Tone Music: A Study of the Sketches for Opp. 17-19, 21, and 22/2 (1924-1930)." Ph.D. diss., Duke University, 1992.
- McKenzie, Wallace C., Jr. "The Music of Anton Webern." Ph.D. diss., North Texas State College, 1960.
- Meyer, Felix, and Sabine-Hänggi-Stampfli. *Anton Webern: Musikmanuskripte*. Inventare der Paul Sacher Stiftung. Winterthur: Amadeus, 1994.
- Moldenhauer, Hans, and Rosaleen Moldenhauer. *Anton von Webern: A Chronicle of His Life and Work*. New York: Knopf, 1979.
- _____. *Anton von Webern: Chronik seines Lebens und Werkes*. Translated by Ken W. Bartlett. Zürich: Atlantis Musikbuch-Verlag AG, 1980.
- Nolan, Catherine. "Hierarchic Linear Structures in Webern's Twelve-Tone Music." Ph.D. diss., Yale University, 1989.

- Noller, Joachim. "Das dodekaphone Volkslied. In *Anton Webern II*, ed. Heinz-Klaus Metzger and Rainer Riehn, 137-50. Munich: Musik-Konzepte Sonderband, 1984.
- Perle, George. "Webern's Twelve-Tone Sketches." *The Musical Quarterly* 7, no. 1 (January 1971): 1-25.
- Reinhardt, Lauriejean. "From Poet's Voice to Composer's Music: Text and Music in Webern's Jone Settings." Ph.D. diss., University of North Carolina at Chapel Hill, 1995.
- _____. "Anton Webern's 'Mein Weg geht jetzt vorüber,' Op. 15, No. 4." In *The Rosaleen Moldenhauer Memorial: Music History from Primary Sources: A Guide to the Moldenhauer Archives*, ed. Jon Newsom and Alfred Mann. Washington: Library of Congress, 2000.
- Rexroth, Dieter, ed. *Opus Anton Webern*. Berlin: Quadriga, 1983.
- Shreffler, Anne. "Webern's Trakl Settings." Ph.D. diss., Harvard University, 1989.
- _____. *Webern and the Lyric Impulse: Songs and Fragments on Poems of Georg Trakl*. Oxford: Oxford University Press, 1994.
- _____. "'Mein Weg geht jetzt vorüber': The Vocal Origins of Webern's Twelve-Tone Composition." *Journal of the American Musicological Society* 47, no. 2 (Summer 1994): 275-339.
- Trembath, Shirley. "Text and Texture in the Solo Vocal Works, Opp. 14-25, of Anton Webern." Ph.D. diss., University of Texas at Austin, 1985.
- Wildgans, Friedrich. *Anton Webern*. Translated by Edith Temple Roberts, and Humphrey Searle. New York: October House, 1967.
- Yorke, Sarah Kathryn. "Opera 15-18 of Anton Webern: Musical Choices Inspired by Text." D.M.A. thesis, University of Cincinnati, 2003.

Secondary Sources: Music Studies

- Jones, Allan Clive. "The Viennese Connection." *Classical Guitar* 7, no. 5 (January 1989): 35-39.
- Marriott, David Franklin, Jr. "Contemporary Guitar Composition: Experimental and Functional Practices since the 'Second Viennese School.'" Ph.D. diss., University of California at San Diego, 1984.
- Marvin, Elizabeth West, and Robert W. Wason. "On Preparing Anton Webern's Early Songs for Performance: A Collaborator's Dialogue." *Theory and Practice* 20 (1995): 91-124.
- Rothstein, William. "Heinrich Schenker as an Interpreter of Beethoven's Piano Sonatas." *19th-Century Music* 8, no. 1 (Summer 1984): 3-28.

Simms, Bryan R. *Schönberg, Berg, and Webern: A Companion to the Second Viennese School*. Westport, Conn.: Greenwood, 1999.

Smith, Joan Allen. *Schoenberg and His Circle: A Viennese Portrait*. New York: Schirmer, 1986.

Stuckenschmidt, H. H. *Schoenberg: His Life, World and Work*. Translated by Humphrey Searle. New York: Schirmer, 1977.

Secondary Sources: Analytical Tools

Bernard, Jonathan. *The Music of Edgard Varèse*. New Haven: Yale University Press, 1987.

Lloyd, Llewelyn S., and Richard Rastall. "Pitch Nomenclature." In *The New Grove Dictionary of Music and Musicians*, 2d ed., ed. Stanley Sadie, 804-7. New York: MacMillan, 2001.

Marvin, Elizabeth West, and Paul A. Laprade. "Relating Musical Contours: Extensions of a Theory for Contour." *Journal of Music Theory* 31, no. 2 (Fall 1987): 225-67.

Morris, Robert D. "New Directions in the Theory and Analysis of Musical Contour." *Music Theory Spectrum* 15, no. 2 (Fall 1993): 205-28.

Straus, Joseph N. *Introduction to Post-Tonal Theory*. Englewood Cliffs, N.J.: Prentice Hall, 1990.

Secondary Sources: Literary

Andraschke, Peter. "Webern und Rosegger." In *Opus Anton Webern*, ed. Dieter Rexroth, 108-12. Berlin: Quadriga, 1983.

Hoermann, Roland. *Achim von Arnim*. Boston: Twayne, 1984.

Huglo, Michel, and Joan Halmo. "Antiphon." In *The New Grove Dictionary of Music and Musicians* 1, ed. Stanley Sadie, 735-48. 2d ed. New York: Macmillan, 2001.

Musical Scores

Webern, Anton. *Drei Lieder für Gesang, Es-Klarinette und Gitarre, Op. 18*. Vienna: Universal Edition, 1954.

Discography

Webern, Anton. 1957. *Anton von Webern: The Complete Recordings*. Robert Craft, conductor. CK4L-232.

_____. 1978. *6 Songs after Georg Trakl, Op. 14 (1917-21); 5 Sacred Songs, Op. 15 (1922-23); 5 Canons, Op. 16; 3 Sacred Folk Songs, Op. 17 (1924); 3 Songs, Op. 18 (1925)*. Amsterdam Ensemble. Robert de Leeuw, conductor. Tel. 642350.

_____. 1978. *Anton Webern: Complete Works, Opp. 1-31*. Pierre Boulez, conductor. 45845.

_____. 2000. *Complete Webern*. Pierre Boulez, conductor. 457 637-2.

* unavailable

BIOGRAPHICAL SKETCH

Lorian Meyer-Wendt was born in Hamilton, New York on 25 September 1974. She attended Vassar College from 1992 to 1996, graduating with general and departmental honors in 1996 with a bachelor of arts degree in music. While at Vassar College, Ms. Meyer-Wendt was a two-time recipient of the Kate Chittenden Memorial Scholarship for summer music study. She worked as a language assistant for the Department of German from 1992 to 1993, then from 1995 to 1996. Ms. Meyer-Wendt came to Florida State University in 1998 and began her studies in music theory, fulfilling coursework requirements in 2000. At Florida State University, she held a teaching assistantship in Music Theory from 1998 to 2000 and was inducted into the Pi Kappa Lambda national music honor society. Following the completion of her coursework, Ms. Meyer-Wendt relocated to Colorado where she began her teaching career. From 2001 to 2003, she founded music and French programs for grades K-8 at St. Louis Catholic School in Englewood, Colorado. In 2003, she began working as an elementary school music teacher at Jefferson Academy, a Core Knowledge charter school located in Broomfield, Colorado. Upon finishing her thesis, Ms. Meyer-Wendt received a master of music degree in music theory in 2004.